

MARINE RADAR

### **MR-1000RⅡ**

(Radome type)

### **MR-1000TⅡ**

(Open array type; 4 kW)

### **MR-1000TⅢ**

(Open array type; 6 kW)



## SYSTEM COMPONENTS

MODEL NAME	CRT DISPLAY	SCANNER UNIT
MR-1000RII	SX-2713 (10-inch CRT)	EX-2714 (Radome type)
MR-1000TII	SX-2779 (10-inch CRT)	EX-2780 (Open array type; 4 kW)
MR-1000TIII	SX-2779 (10-inch CRT)	EX-2780 (Open array type; 6 kW)

## SUPPLIED ACCESSORIES

### •EX-2714 (Radome type unit)

	Qty.
① System cable (OPC-1188A: 15 m) .....	1
② Installation bolts (M10×50) .....	4
③ Installation bolts (M10×25) .....	4
④ Installation nuts (M10) .....	4
⑤ Flat washers (M10) .....	4
⑥ Spring washers (M10) .....	4

### •EX-2780 (Open array type unit)

	Qty.
① System cable (OPC-1189A: 20 m) .....	1
② Installation bolts (M10×40) .....	4
③ Installation nuts (M10) .....	4
④ Flat washers (M10) .....	4
⑤ Spring washers (M10) .....	4
⑥ Hex head wrench .....	1
⑦ Cap bolts (M8×18) .....	4
⑧ Dish washers (M8) .....	4
⑨ Sealing washers (T) .....	4
⑩ Flat washers (M8) .....	4
⑪ Grounding terminal (R5.5-10) .....	1
⑫ Ferrite bead .....	1

### •SX-2713/2779 (10 inch CRT display unit)

	Qty.
① NMEA connector (FM14-8P) .....	1
② Spare fuse (FGB 10 A) .....	1
③ Spare fuse (FGB 5 A: for over 24 V power supply) .....	1
④ DC power cable (OPC-928-2) .....	1
⑤ Viewing hood (2363 HOOD) .....	1
⑥ Mounting bracket (2363 ANGLE(A)) .....	1
⑦ Mounting screw knobs (2363 KNOB BOLT) .....	2
⑧ Self-tapping screws (M6 × 30) .....	5
⑨ Spring washers (M6) .....	5
⑩ Flat washers (M6) .....	5
⑪ Instruction manual .....	1
⑫ Operating guide .....	1
⑬ NMEA connector (FM14-7P) .....	1

---

## FOREWORD

---

Thank you for purchasing Icom's **MR-1000RII/TII/TIII MARINE RADAR**.

The radar is designed especially for fishing boats. It has powerful transmission power, 10 inch CRT display and many other advanced features.

If you have any questions regarding the operation of the radar, contact your nearest authorized Icom Inc. dealer.

---

## IMPORTANT

---

**READ ALL INSTRUCTIONS** carefully and completely before attempting to operate the marine radar.

**SAVE THIS INSTRUCTION MANUAL.** This manual contains important safety and operating instructions for the MR-1000RII/TII/TIII.

---

## EXPLICIT DEFINITIONS

---

The following explicit definitions apply to this instruction manual.

WORD	DEFINITION
<b>⚠ WARNING</b>	Personal injury, fire hazard or electric shock may occur.
<b>CAUTION</b>	Equipment damage may occur.
<b>NOTE</b>	If disregarded, inconvenience only. No risk of personal injury, fire or electric shock.

---

## PRECAUTION

---

**⚠ NEVER** let metal, wire or other objects touch any internal part of the radar.

**⚠ NEVER** place the radar within the reach of children.

**⚠ NEVER** expose the display unit to rain, salt water or any other liquids.

**NEVER** connect the radar to AC or more than 42 V DC. This will damage the radar.

**AVOID** using the radar near any magnetic materials, such as a loudspeaker or a large power transformer, as this can cause distortion of the CRT display.

**AVOID** placing the display unit in excessively dusty environments.

**AVOID** placing the display unit near heating equipment or in direct sunlight or where hot or cold air blows directly onto it.

**AVOID** using the scanner unit in areas where the temperature is below  $-25^{\circ}\text{C}$  ( $-13^{\circ}\text{F}$ ) or above  $+70^{\circ}\text{C}$  ( $+158^{\circ}\text{F}$ ). **AVOID** using the display unit in areas where the temperature is below  $-15^{\circ}\text{C}$  ( $+5^{\circ}\text{F}$ ) or above  $+55^{\circ}\text{C}$  ( $+131^{\circ}\text{F}$ ).

**AVOID** using strong solvents such as benzene or alcohol for cleaning the radar, as they may damage the surfaces.

### BE CAREFUL!

**SART** signal may not be detected and may not be displayed on the screen depending on the **SEA**, **RAIN** or **IR** settings.

Follow the settings as below to detect the **SART** signal on the screen.

- ① Select the screen range between 6 NM to 12 NM with **[+/-]**. (p. 2)
- ② Set the **[GAIN]** as high as possible. (p. 3)
- ③ Set the **[SEA]** to minimum. (p. 3)
- ④ Set the **[RAIN]** to minimum. (p. 3)
- ⑤ Turn the **[IR]** OFF.
- ⑥ Turn the **[STRETCH]** OFF.

---

# TABLE OF CONTENTS

---

SYSTEM COMPONENTS.....	i	<b>8 BASIC RADAR THEORY .....</b>	<b>21–23</b>
SUPPLIED ACCESSORIES.....	i	■ Side-lobe echoes .....	21
FOREWORD .....	ii	■ Indirect echoes .....	21
IMPORTANT .....	ii	■ Multiple echoes .....	22
EXPLICIT DEFINITIONS .....	ii	■ Minimum range .....	22
PRECAUTION .....	ii	■ Blind and Shadow sectors .....	23
TABLE OF CONTENTS .....	iii	■ Target resolution.....	23
<b>1 CAUTION .....</b>	<b>1</b>	<b>9 INSTALLATION AND CONNECTIONS .....</b>	<b>24–30</b>
DANGER! HIGH VOLTAGE .....	1	■ Connecting the units .....	24
RADIATION HAZARD .....	1	■ Power source requirement .....	24
<b>2 PANEL DESCRIPTION .....</b>	<b>2–5</b>	■ Ground connection .....	24
■ Front panel .....	2	■ Installing the display unit .....	25
■ Screen .....	4	■ Mounting the EX-2714 scanner unit .....	26
<b>3 MENU .....</b>	<b>6–7</b>	■ Wiring the EX-2714 system cable .....	27
■ VIDEO .....	6	■ Mounting the EX-2780 scanner unit .....	28
■ FUNCTION.....	6	■ Wiring the EX-2780 system cable .....	29
■ ATA (Automatic Tracking Aid) .....	7	■ Fixing the EX-2780 scanner unit .....	30
■ INT. SETTING .....	7	<b>10 OTHER FUNCTIONS .....</b>	<b>31</b>
<b>4 BASIC OPERATION .....</b>	<b>8–13</b>	<b>11 SERVICE MAN MENU .....</b>	<b>32–34</b>
■ Checking the installation .....	8	■ Service man menu .....	32
■ Turning power ON/OFF .....	8	■ Select the language .....	32
■ Basic operation .....	9	■ TIMING adjustment .....	33
■ RAIN function .....	10	■ HDG adjustment.....	33
■ SEA function.....	10	■ SPD adjustment .....	34
■ OFF CENTER function.....	10	■ RANGE selection .....	34
■ IR function .....	11	<b>12 ERROR MESSAGE .....</b>	<b>35</b>
■ STRETCH function .....	11	■ Error message list .....	35
■ ZOOM function .....	11	<b>13 MAINTENANCE .....</b>	<b>36</b>
■ TRAILS function .....	12	■ Periodic maintenance .....	36
■ Power save function .....	12	■ Scanner unit maintenance .....	36
■ Ship speed indication .....	13	■ Display unit maintenance .....	36
■ Position indication .....	13	■ Options .....	36
■ Waypoint indication .....	13	<b>14 SPECIFICATIONS .....</b>	<b>37–38</b>
■ Long pulse function .....	13	<b>15 EXTERNAL DATA LIST .....</b>	<b>39</b>
■ Bearing setting .....	13	<b>(Supplement) TEMPLATE</b>	
<b>5 DISTANCE AND DIRECTION</b>		■ Template for the display unit	
<b>MEASUREMENTS .....</b>	<b>14–16</b>	• SX-2713/2779 (Display mount bracket template)	
■ Distance measurement .....	14	■ Template for the scanner unit	
■ Bearing and Distance measurement .....	15	• EX-2714	
■ Advanced measurements .....	16	• EX-2780	
<b>6 ALARM FUNCTION .....</b>	<b>17</b>		
■ Alarm zone setting .....	17		
■ Zone alarm setting .....	17		
<b>7 ATA (Automatic Tracking Aid) .....</b>	<b>18–20</b>		
■ ATA (Automatic Tracking Aid) .....	18		
■ ATA menu setting .....	18		
■ ATA operation .....	19		
■ Plotting marks .....	19		
■ Course and speed vector .....	19		
■ Plots .....	20		

The MR-1000RII/TII/TIII are supplemental aids to navigation and are not intended to be a substitute for accurate and current nautical charts.

---

**DANGER! HIGH VOLTAGE**

---

**• NEVER OPEN THE UNIT**

This product contains high voltage that could be FATAL. This product has no user-serviceable parts inside. All repairs and adjustments MUST be made by a qualified electronics technician at your Marine Navigation Dealer.

**• HIGH VOLTAGE**

High voltages of up to 3,500 volts are used in this equipment. Although prudent measures for safety have been adopted, sufficient care must be taken in the operation, maintenance and adjustment of the equipment.

Electric shock of 1,000 volts or more may cause electrocution and death; even an electric shock of only 100 volts may be fatal.

**• PREVENTION OF ELECTRIC SHOCK  
(FOR QUALIFIED ELECTRONIC TECHNICIANS ONLY)**

To prevent such accidents, turn OFF the power source and do not reach inside the unit until you have:

- ① discharged the capacitors by disconnecting the power cable from the power source for 5 min.;
- ② checked that no electric charges remain inside the device.

Also, it is safest to wear dry insulated rubber gloves. NEVER use both hands simultaneously; keep one hand in your pocket.

---

**RADIATION HAZARD**

---

Radiation emitted from the scanner unit can be harmful, particularly to the eyes. To avoid harmful radiation, ensure the radar power is in the OFF position before beginning work on the scanner unit.

## Front panel

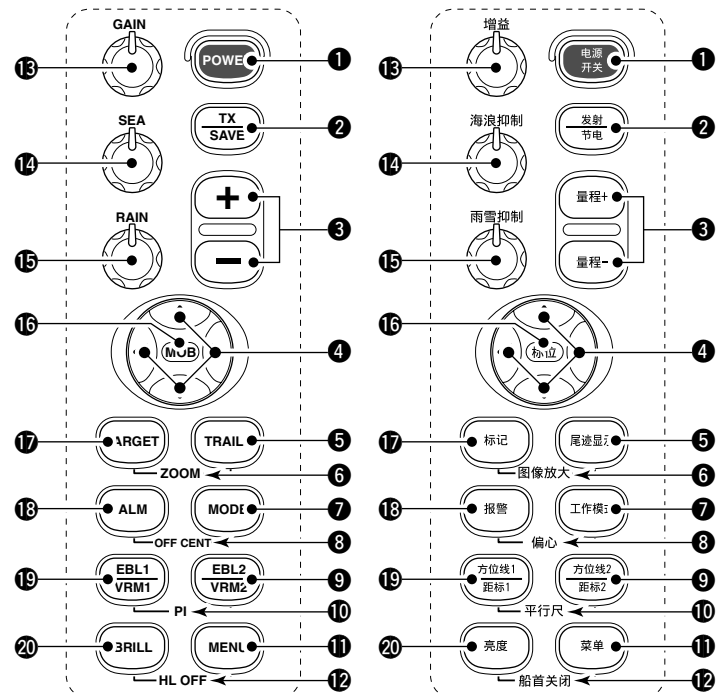
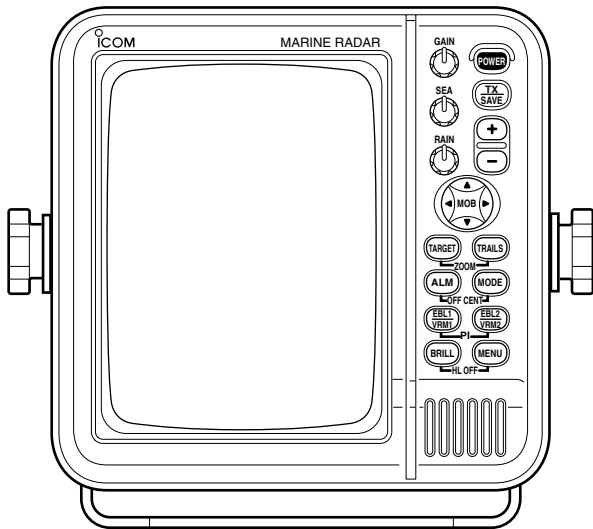

Control panel (English)

Control panel (Chinese)

### 1 POWER SWITCH [POWER]/[电源开关] (p. 8)

Turns power ON and OFF.

- The standby screen appears for 90 sec. while warming up the magnetron.
- The initial screen appears with a beep after the power has been turned ON.

### 2 TRANSMIT/SAVE SWITCH [TX (SAVE)]

[发射/节电]

- ➔ Push to toggle between the TX mode and the standby mode. (p. 9)
- ➔ Push and hold for 1 sec. to turn the power save function ON. The radar for TX interval scan is fixed at 10 revolutions. (p. 12)
- Select the save time in INT. SETTING menu.

### 3 RANGE UP/ DOWN SWITCHES [+]/[-]

[量程+]/[量程-] (p. 9)

- Push [+] to increase the screen range.
- Push [-] to decrease the screen range.

### 4 UP, DOWN, LEFT, RIGHT KEYS [▲▼◀▶]

Set the EBLs, VRMs, alarm area, ATA target, etc. according to the key pushed.

Use the [▲] [▼] to select menu item and [◀] [▶] to set the item.

Using the [▲◀]/[▲▶] or [▼◀]/[▼▶] combination allows you to move the cross line cursor to the upper (or lower) left or right.

### 5 TRAILS SWITCH [TRAILS]/[尾迹显示] (p. 12)

Push to toggle the trail function ON and OFF. This is useful for watching other ship's tracks, approx. relative speed etc.

- Trail Time can be set in VIDEO menu.

### 6 ZOOM FUNCTION [ZOOM]/[图像放大] (p. 11)

Push [TARGET]/[标记] and [TRAILS]/[尾迹显示] simultaneously to toggle the ZOOM function ON and OFF. ZOOM function expands the target to 2 times normal.

- Move the cursor to the target, then turn the function ON.
- The screen zooms around the middle of the cursor and own ship.
- This function is not available on 1/8 and 32 NM or above ranges.

### 7 MODE SWITCH [MODE]/[工作模式]

Push to select one of Head-up (H UP), Course-up (C UP), North-up (N UP) or True motion (TM) screens.

- The North-up and Course-up screens can be selected only when a bearing data format is connected. (p. 39)
- TM screen requires bearing data and LOG or position data. (p. 39)
- TM screen is not available at 32 NM or above range.

### 8 OFF CENTER FUNCTION [OFF CENT]/[偏心]

(p. 10)

Push [ALM]/[报警] and [MODE]/[工作模式] simultaneously to turn the OFF CENTER function ON or OFF.

- This function is available for 24NM or shorter range selection.

**9 EBL2 (VRM2) SWITCH [EBL2 (VRM2)]**

/[方位线2(距标2)] (pgs. 15–16)

Push to display the electronic bearing line 2 (EBL2) and the variable range marker 2 (VRM2), and activate the [◀ ▶] for the electronic bearing line selector and [▲ ▼] for the range marker selector.

- When the VRM1 and EBL1 (49 52) are displayed, the center of VRM2 appears at the intersection point of the VRM1 and EBL1.

**10 PARALLEL INDEX LINE FUNCTION [PI]/[平行尺]**

Push [EBL1]/[方位线1(距标1)] and [EBL2]/[方位线2(距标2)] simultaneously to toggle the parallel index line ON and OFF.

- Push [◀ ▶] keys to rotate the lines, and push [▲ ▼] keys to adjust the line spaces.

**11 MENU SWITCH [MENU]/[菜单]** (pgs. 6–7)

Push [MENU]/[菜单] to toggle the VIDEO, FUNCTION, ATA, INT. SETTING and SERVICE MAN menu. Push [▲ ▼] keys to select the items and push [◀ ▶] keys to change the setting.

**12 HEADING LINE OFF FUNCTION [HL OFF]**

/[船首关闭] (p. 9)

Push [BRILL]/[亮度] and [MENU]/[菜单] simultaneously to turn off the heading line temporarily.

**13 GAIN CONTROL [GAIN]/[增益]** (p. 9)

Adjusts the receiver amplifier gain.

- Clockwise rotation increases the gain
- Increased gain may increase screen noise.

**14 SEA CLUTTER CONTROL [SEA]/[海浪抑制]**

(p. 10)

This function serves to eliminate echoes from the waves at close range.

Reduces the receiver gain for close objects within a radius of 8 nautical miles (approx.) to eliminate sea clutter.

Rotate the control fully clockwise to activate the automatic SEA control function. SEA indicator (26) appears in the upper left of the screen.

- Under normal conditions set the SEA to a minimum.
- Use this control with caution when the sea is rough.

**15 RAIN CLUTTER CONTROL [RAIN]/[雨雪抑制]**

(p. 10)

This function eliminates reflection echoes from rain, snow, fog, etc.

Rotate the control fully counter clockwise to deactivate the RAIN function.

RAIN indicator (28) disappears.

**16 MAN OVERBOARD [MOB]/[标位]**

Push to mark the man overboard point on the screen. When a crew member falls overboard, push [MOB]/[标位] for 1 sec. to display the MOB symbol (☑) on the screen.

- MOB readout shows the bearing, distance and estimated time to the MOB point with current speed.
- Push [MOB]/[标位] for 1 sec. to cancel the function.
- Position and bearing data are necessary.

**17 TARGET SWITCH [ATA]/[标记]** (pgs. 18–20)

A setup of target caught by ATA (up to 10 targets can be set).

- Push [▲ ▼ ◀ ▶] to move the cross cursor on the echo which you want to plot on the screen before turning the function ON.
- Select “ATA” function ON in the “ATA” menu, set the appropriate No. DISP, VECT, OWN VECT, ALARM, CPA LIMIT and TCPA LIMIT setting.

**18 ALARM SWITCH [ALM]/[报警]** (p. 17)

Push [ALM]/[报警] to toggle the alarm function ON and OFF.

Push and hold [ALM] for 1 sec. to enter the alarm area setting condition.

- Push [▲ ▼ ◀ ▶] to move the cross cursor to the zone starting point, then push [ALM] for 1 sec. The starting ring of the zone is created. Then push [▲ ▼ ◀ ▶] to fix the finish point, the desired alarm zone will automatically form.

**19 EBL1 (VRM1) SWITCH [EBL1 (VRM1)]**

/[方位线1(距标1)] (pgs. 15–16)

Push to display the electronic bearing line 1 (EBL1) and the variable range marker 1 (VRM1) and activate the [◀ ▶] for the electronic bearing line selector, and [▲ ▼] for the range marker selector.

- EBL1 bearing and VRM1 distance are displayed, in the bottom window.
- When EBL1 and VRM1 are displayed, the beginning of EBL2 appears at the intersection point of EBL1 and VRM1.

**20 DISPLAY BRILLIANCE SWITCH [BRILL]/[亮度]**

(p. 9)

➔ Push to increase or decrease the brilliance of the picture on the display.

➔ Push for 1 sec. to select the maximum brilliance.

- The brightness of the symbol, character and illumination can be adjusted in the “SYMBOL”, “CHARACTER” and “KEY ILLUM” of the INT. SETTING menu independently.

■ Screen

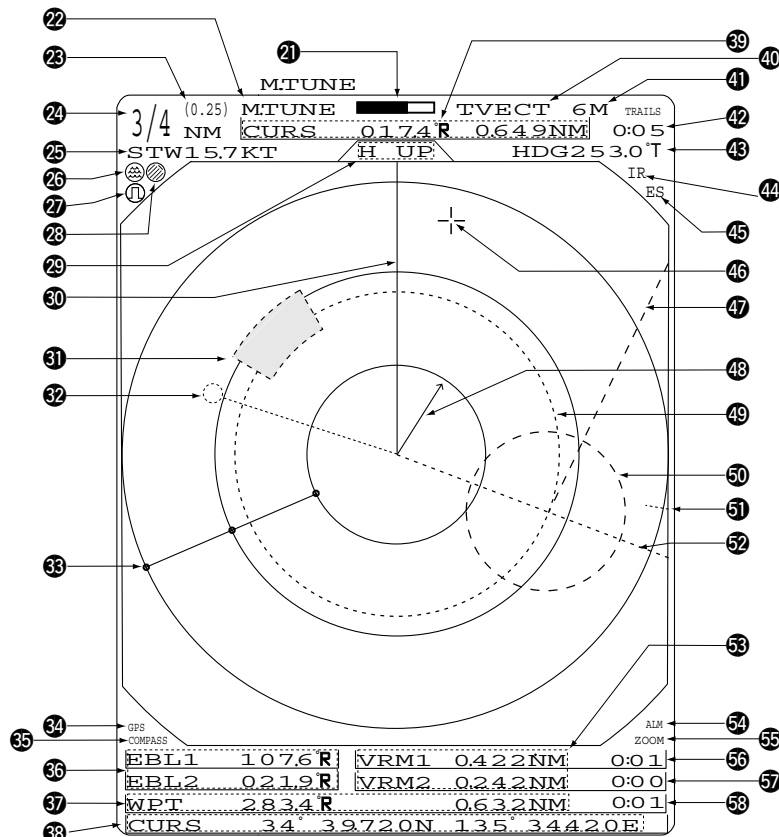

- 21 TUNING LEVEL INDICATOR** (p. 9)  
Shows the receiver tuning level.
- 22 TUNING MODE INDICATOR** (p. 9)  
“M.TUNE” appears when the manual tuning function is in use.
- 23 FIXED RING RANGE READOUT** (p. 14)  
Shows the interval range of the fixed ring.  
• This readout appears when the “RING” of the FUNCTION menu is turned ON.
- 24 SCREEN RANGE READOUT** (p. 14)  
Shows the maximum range of the displayed screen.  
• The range indicated is nautical miles (NM).
- 25 SHIP SPEED READOUT** (p. 13)  
Shows the ship speed.  
• SOG: When GPS is selected in the INT. SETTING menu.  
• STW: When LOG is selected in the INT. SETTING menu.
- 26 AUTO SEA INDICATOR** (p. 10)  
Appears when the automatic SEA control function is turned ON.
- 27 LONG PULSE INDICATOR** (p. 13)  
Appears when the long pulse is in use.
- 28 RAIN CONTROL INDICATOR** (p. 10)  
Appears when the RAIN function is in use.
- 29 MODE INDICATOR**  
Head-up, Course-up, North-up and True Motion screens are available.  
• NUP and CUP screens require external bearing data. (p. 39)  
• TM screen requires bearing data and LOG or position data.
- 30 HEADING LINE** (p. 9)  
Heading line indicates the ships bow.
- 31 ALARM ZONE** (p. 17)  
Shows the alarm zone.  
• Appears when the alarm function is in use.
- 32 WAYPOINT MARKER** (p. 13)  
Shows the waypoint received from navigation equipment.  
• This marker appears when the “WPT” of the FUNCTION menu is turned ON.  
• To display the waypoint marker, bearing data and NMEA data with 0183 format is necessary. (p. 39)
- 33 FIXED RANGE RINGS** (p. 14)  
Shows the distance in fixed intervals. The interval distance is indicated by the ring range readout (23).  
• These rings appear when the “RING” of the FUNCTION is turned ON.
- 34 GPS indicator** (p. 24)  
Indicator appears when the GPS or DGPS receiver is connected.



- 35 COMPASS INDICATOR** (pgs. 24, 39)

  - GYRO : NMEA (gyro) is connected.
  - COMPASS : NMEA (compass), N+1 or AUX data is connected.
- 36 EBL1/ 2 READOUTS** (pgs. 15–16)

Shows the bearing of the displayed Electronic Bearing Lines (EBL1 and EBL2) when the EBL is in use.

  - EBL2 shows PI (10) readout.
- 37 WAYPOINT/MOB READOUTS** (p. 13)

  - ➔ Shows the bearing and distance to the waypoint received from navigation equipment.
    - This readout appears when the “WPT” of the FUNCTION menu is turned ON.
    - To display the waypoint/MOB marker, bearing data and NMEA data with 0183 format is necessary. (p. 39)
  - ➔ Shows the bearing and distance to the MOB (Man Over Board) event marker.
    - Push [MOB]/[ 标位 ] to cancel the readout and the symbol.
- 38 POSITION/CURSOR READOUT** (p. 13)

Shows your own ship or cursor latitude and longitude readout when external NMEA data with 0183 format is connected.

  - Select ‘SHIP’ or ‘CURS’ in the “POSN DISP” of the FUNCTION menu.
  - To display the POSITION; NMEA 0183 is necessary.
  - To display the CURSOR; NMEA 0183 and bearing data are necessary.
- 39 CURSOR INDICATOR**

Shows the bearing and distance to the cursor.
- 40 VECTOR INDICATOR** (p. 18)

Shows the ATA and OWN vector type.

  - T: True vector
  - R: Relative vector
- 41 VECTOR TIME INDICATOR** (p. 18)

Shows the vector interval time. Select vector time in the “TRAIL TIME” of the VIDEO menu.

  - 30 min. is applied, when ‘∞’ is selected for the vector time.
- 42 TRAILS INDICATOR** (p. 12)

Shows the trail time.

  - Echo remains with gradation during the trail time period on the screen. (Except for the trail time; ∞)
  - Progressing time counter starts to count the time until the timer reaches the trail time.
- 43 HEADING INDICATOR**

Shows the heading bearing readout.

  - The HDG readout indicates the bow of the ship’s bearing in a clockwise direction from north.
- 44 IR INDICATOR** (p. 11)

Eliminates or reduces interference caused by other radar operating nearby.

  - This function is available when the “IR” in the VIDEO menu is set to 1 or 2.
- 45 ECHO STRETCH INDICATOR** (p. 6)

Appears when the echo stretch function is in use.

  - This function is available when the “STRETCH” of the VIDEO menu is turned ON.
- 46 CROSS LINE CURSOR**

Used for measuring the bearing and distance, setting the alarm zone, selecting the ATA targets, etc.

  - Push [▲ ▼ ◀ ▶] several times to move the cursor.
- 47 EBL2** (pgs. 15–16)

Used for bearing measurement. When a target is selected, the EBL readout (36) shows the bearing.
- 48 OWN SHIP VECTOR INDICATOR**

Shows the vector of your own ship.
- 49 VRM 1** (pgs. 15–16)
- 50 VRM 2** (pgs. 15–16)

Used for distance measurement. When a target is selected, the VRM1/2 readout (53) shows the distance.
- 51 NORTH MARK**

The north mark shows the true north direction.
- 52 EBL1** (pgs. 15–16)

Used for bearing measurement. When a target is selected, the EBL readout (36) shows the bearing.
- 53 VRM1/2 READOUTS** (pgs. 15–16)

Shows the distance of the displayed Variable Range Markers (VRM1 and VRM2) when the VRM is in use.

  - Nautical miles (NM) and kilometers (KM) can be selected in the FUNCTION menu as the distance unit.
- 54 ALARM INDICATOR** (p. 17)

Appears when the alarm function is in use.
- 55 ZOOM INDICATOR** (p. 11)

Appears when the zoom function is in use.

  - Push [TARGET]/[ 标记 ] and [TRAILS]/[ 尾迹显示 ] simultaneously to turn the function ON or OFF.
- 56 TIME INDICATOR**
- 57 TIME INDICATOR**

Shows the estimated time to the marker edge from center of the marker with current speed.
- 58 TIME INDICATOR**

Shows the estimated time to the waypoint with current speed.

## VIDEO

VIDEO MENU				
TUNE	AUTO	MANUAL		
D.RANGE	NAR.	MID.	WIDE	
IR	OFF	1	2	
STRETCH	OFF	ON		
PULSE	SP	LP		
SEA	1 2 3 4			
TRAIL TIME	6S 15S 30S 1M			
	3M 6M 15M ∞			

### ◇ TUNE

- **AUTO** : Automatic tuning.
  - "A.TUNE" appears for approx. 2 sec. instead of the screen display, when first transmitting after turning the power ON. The unit also re-tunes in some cases.
- **MANUAL** : Manual tuning.
  - Push [▶] to select [MANUAL] then push [▼] to activate the manual tuning slider. Push [◀▶] to adjust desired tuning level.

### ◇ D.RANGE

Select the dynamic range of the PPI (Plan Position Indicator).

- **NAR.** : Narrow dynamic range. Even weak reflections are displayed as strong reflections.
- **MID.** : Mid dynamic range.
- **WIDE** : Wide dynamic range. You can distinguish between weak reflections and strong reflections easily.

### ◇ IR

- **OFF** : Turn the Interference Reduction function OFF.
- **1 or 2 (ON)** : Turn the Interference Reduction function 1 (Low) or 2 (High).

### ◇ STRETCH

- **OFF** : Turn the echo stretch function OFF.
- **ON** : Turn the echo stretch function ON.

### ◇ PULSE

- **SP** : Select the short pulse.
- **LP** : Select the long pulse. LP indicator appears on the screen.

### ◇ SEA

- The characteristic (curve) of a SEA knob can be chosen as the optimal characteristic out of four kinds with the height of an antenna.

### ◇ TRAIL TIME

- **6S, 15S, 30S, 1M, 3M, 6M, 15M or ∞** : Select the plot interval and vector time.

## FUNCTION

FUNCTIONMENU			
<b>RING</b>	OFF	ON	
WPT	OFF	ON	
POSN DISP	SHIP	CURS	
DIST UNIT	NM	KM	
BRG	TRUE	MAG	
EBL/PI	TRUE	360°R	PT/SB
ZONE ALARM	IN	OUT	
BEEP	OFF	ON	

### ◇ RING

- **OFF** : Turn the fixed range ring display OFF.
- **ON** : Turn the fixed range ring display ON.

### ◇ WPT

- **OFF** : Non display the way point on the screen.
- **ON** : Display the way point on the screen.

### ◇ POSN DISP

- **SHIP** : Display your own ship's position.\*
- **CURS** : Display the cursor position.\*\*
- \* External latitude/longitude data required.
- \*\* External latitude/longitude data and bearing data required.

### ◇ DIST UNIT

- **NM** : Display the distance unit in Nautical Mile.
- **KM** : Display the distance unit in Kilometer.

### ◇ BRG

Select the displayed bearing type, no relation with the bearing data format (NMEA, N+1 or AUX).

- **TRUE** : Select the true bearing.
- **MAG** : Select the magnetic bearing.

### ◇ EBL/PI (except HDG and CSE) (p. 15)

- **TRUE** : True or magnetic direction.
- **360°R** : Relative direction
- **PT/SB** : Bow direction

### ◇ ZONE ALARM

- **IN** : Alarm is emitted when the target comes into the zone.
- **OUT** : Alarm is emitted when the target goes out of the zone.

### ◇ BEEP

- **OFF** : Turn the beep tone OFF\*.
- **ON** : Turn the beep tone ON.
- \* Except alarm function.

## ■ ATA (Automatic Tracking Aid)

A T A M E N U			
<b>ATA</b>	<b>OFF</b>	ON	
No.DISP	OFF	<b>SEL</b>	ALL
VECT	<b>TRUE</b>	REL	
OWN VECT	<b>OFF</b>	ON	
ALARM	<b>OFF</b>	ON	
CPA LIMIT	1.0NM		
TCPA LIMIT	1 MIN		

### ◇ ATA

- OFF : Turn the ATA function OFF.
- ON : Turn the ATA function ON.

### ◇ No.DISP

- OFF : Non display any mark number.
- Sel : Display the selected mark number only.
- ALL : Display all mark numbers.

### ◇ VECT

- TRUE : Select the true vector mode.
- REL : Select the relative vector mode.

### ◇ OWN VECT

- OFF : Non display the own ship vector.
- ON : Display your own ship's vector.

### ◇ ALARM (CPA/TCPA)

- OFF : Turn the alarm function OFF.
- ON : Turn the alarm function ON.

### ◇ CPA\* LIMIT

- 0.1 to 10.0NM : Set the CPA (Closest Point of Approach) limit with [◀ ▶].

### ◇ TCPA\* LIMIT

- 1 to 60MIN : Set the TCPA (Time to CPA) limit time with [◀ ▶].

\*CPA/TCPA: Closest Point of Approach and Time to Closest Point of Approach limit is defined by the observer to given warning when a target or targets are close to within those limits from your own ship.

## ■ INT. SETTING

I N T . S E T T I N G			
<b>MAG VAR</b>	<b>AUTO</b>	MANUAL	7.2° W
BRG INPUT	<b>NMEA</b>	N+1	AUX GPS
SPD INPUT	<b>GPS</b>	LOG	
TX INH START	0°		
TX INH ANGLE	0°		
SAVE TIME	1M	<b>6M</b>	15M 30M
SYMBOL	<b>1</b>	2	3
CHARACTER	1	<b>2</b>	3
KEY ILLUM	1	2	3 <b>4</b>

### ◇ MAG VAR

- AUTO : Revise magnetic variation automatically.  
**NOTE:** NMEA data is required. **NEVER** select "AUTO" without NMEA data, incorrect variation data may entered. (p. 39)
- MANUAL : Revise magnetic variation manually.  
•Push [▶] to select [MANUAL], then push [▼]. Set the revise value with [◀ ▶]. Push [▼] or [MENU] to abort the menu.

### ◇ BRG INPUT

- NMEA : NMEA0183 bearing data format.
- N+1 : N+1 data format.
- AUX : Other format.
- GPS : Reads NMEA0183 COG format data as HDG format.

### ◇ SPD INPUT

- GPS : Use the GPS NMEA speed data.
- LOG : Use the speed sensor data.

### ◇ TX INH START

- 0 to 359° : Push [◀ ▶] to enter the start point of the TX inhibit area.

### ◇ TX INH ANGLE

- 0 to 90° : Push [◀ ▶] to enter the TX inhibit area.

### ◇ SAVE TIME

- 1M, 6M, 15M or 30M : Select the stand by time during save mode.

\* The radar for TX interval scan is fixed at 10 revolutions.

### ◇ SYMBOL

- 1/2/3 : Select the symbol brightness.

### ◇ CHARACTER

- 1/2/3 : Select the character brightness.

### ◇ KEY ILLUM

- 1/2/3/4 : Select the key illumination brightness.

## ■ Checking the installation

Before turning the power ON, be sure all the connections are complete. The checklist at right may be helpful for necessary confirmation.

**CAUTION:** Connect the scanner unit before turning the power ON. Otherwise the magnetron inside the scanner unit might be damaged.

### ◇ Checklist

- ① The 4 bolts securing the scanner unit must be firmly tightened.
- ② Cabling must be securely attached to a mast or mounting material, and must not interfere with the rigging.
- ③ Be sure waterproofing procedures are completed on the system cable.
- ④ The power connections to the battery must be of the correct polarity.
- ⑤ Be sure that the plugs at the rear of the display unit have been connected correctly and securely.  
(See p. 24 for details.)

## ■ Turning power ON/OFF

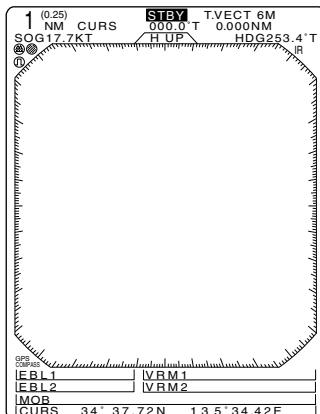
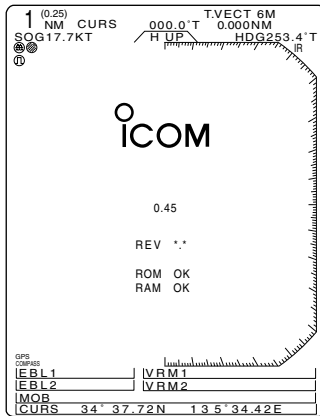

- ① Push [POWER]/[电源开关] to turn the power ON.
  - The initial screen appears and warming up time is counted down on the screen.
  - The magnetron inside the scanner unit warms up for 90 sec.
  - [POWER]/[电源开关] does not function for 2 sec. after the power is turned OFF.
- ② When the countdown is completed, the Standby screen appears.
- ③ Push [TX]/[发射(节电)] to start scanning and select the Plan Position Indicator (PPI) screen.
  - Targets and heading marker appear.
  - The screen appears approx. 2 sec. after turning the power on, when 'AUTO' is selected in the "TUNE" of the VIDEO menu.
- ④ Push [POWER]/[电源开关] to turn the power OFF.

## Basic operation

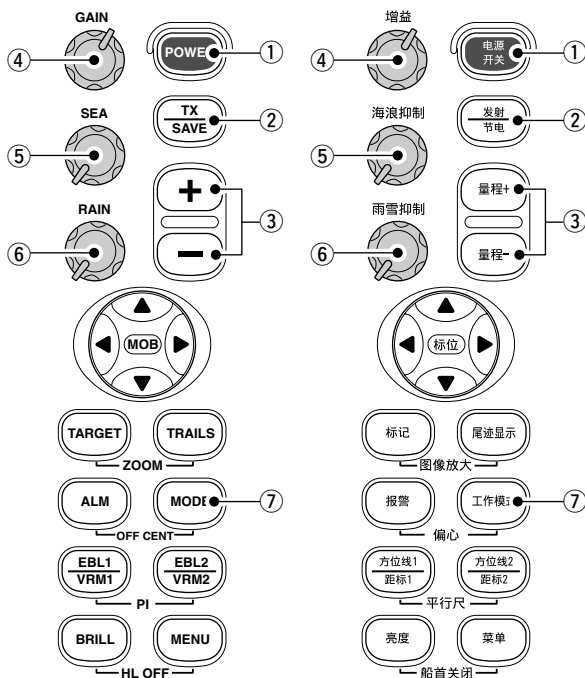

**CAUTION:** When setting the [SEA]/[海浪抑制] control to a fully clockwise position, close targets are blanked.

### ◇ Heading marker

The heading marker is a line that shows your ship's bow direction. (This marker will appear in the center of the screen when the Head-up screen H UP is selected.) The heading marker can be hidden when the desired target is located under the heading marker.

- Push and hold [BRILL]/[亮度] and [MENU]/[菜单] simultaneously to hide the heading marker.

### ◇ Fixed range rings

The fixed range rings can be used for rough distance measurement. (p. 14)

Push [MENU]/[菜单] to open the FUNCTION menu, then push [▼] to select RING. Push [▶] to turn the ring ON.

- ① Turn the power ON.
- ② Push [TX]/[发射(节电)] after the countdown disappears from the screen.
  - See "Turning power ON/OFF" on page at left.
- ③ Push [+]/[量程+] or [-]/[量程-] several times to select the display range.
  - The screen range readout shows the maximum range of the screen.
- ④ Turn [GAIN]/[增益] to set 1 o'clock position.
  - Clockwise rotation increases the gain.
  - Increased gain may increase screen noise.
- ⑤ Turn [SEA]/[海浪抑制] to set the sensitivity time control for minimum.
- ⑥ Turn [RAIN]/[雨雪抑制] to set the rain clutter control for minimum.
- ⑦ Push [MODE]/[工作模式] to select one of Head-up;H UP, Course-up;C UP, North-up;N UP or True Motion;TM screens.
  - C UP, N UP or TM can be selected only when bearing, position or speed data are connected. (See p. 39 for details)

**NOTE:** Manual adjustment can be used. (See below.)

### ◇ Manual tuning

The receiver tuning can be manually adjusted.

Push [MENU]/[菜单] to open the VIDEO menu, then select MANUAL. Push [▼] to activate the manual tuning slider, then push [◀ ▶] to set the tuning level indicator to the maximum level. (p. 6)

- "M.TUNE" appears on the top of the display.

### ◇ Brilliance adjustment

The intensity of the screen can be adjusted. When you require continuous operation, but not constant viewing, a lower setting can increase the life of the CRT display.

**NOTE:** High intensity will shorten the life of the CRT display.

### • Key illumination

The backlighting of the keys can be adjusted for convenient operation. (p. 7)

Push [MENU]/[菜单] four times to call up the INT. SETTING menu. Push [◀ ▶] to select the illumination level.

- Key illumination corresponds with [BRILL]/[亮度] control.

## 4 BASIC OPERATION

The following are typical basic operation examples, which may hinder radar reception (sea clutter, precipitation interference and echoes from other radar).

### ■ RAIN function

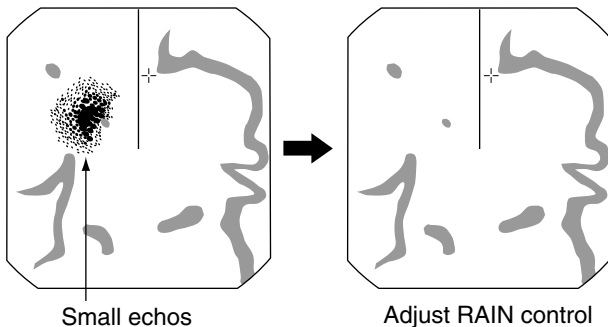

This function eliminates reflection echoes from rain, snow, fog etc.

- Rotate the control fully counterclockwise to deactivate the control function. The RAIN indicator (☉) disappears.
- **NOTE: DO NOT** reduce the reflection echoes too much, otherwise you may miss weaker targets.

### ■ SEA function

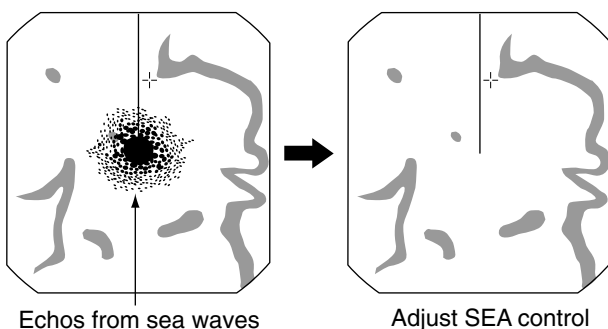

This function serves to eliminate echoes from waves at close range. Reduce the receiver gain for close objects within a radius of 8 miles to eliminate sea clutter.

- Rotate the control fully clockwise to activate the automatic control function. SEA indicator (☉) appears in the upper left of the screen.

**WARNING:** The [SEA]/[海浪抑制] control reduces the receiver sensitivity of objects within 8 miles. Therefore, caution and careful adjustment are necessary when using the [SEA]/[海浪抑制] control. Small objects may not be displayed on the screen when strong echoes from the rain or the island within 1 NM while automatic SEA function is activating.

### ■ OFF CENTER function

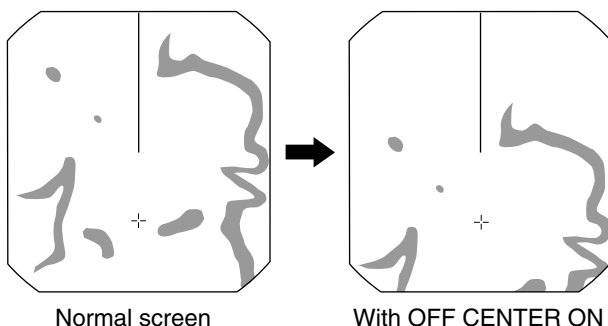

The scanning area can be shifted in a desired direction and can be enlarged partially. This is useful when the Head-up\* is selected and you want to enlarge the bow direction display, or, the center of the screen shifts in the direction of the intersection.

- This function is available for 24NM or shorter range selection.

\*This function is not available in the TM screen.

- ① Push [▲ ▼ ◀ ▶] to move the cursor where you want to shift the center of the screen.
  - Max. offsetting is up to 75% of the screen.
- ② Push [ALM]/[报警] and [MODE]/[工作模式] simultaneously to shift the screen.
- ③ Push [ALM]/[报警] and [MODE]/[工作模式] simultaneously again to return to the normal screen.

## ■ IR function

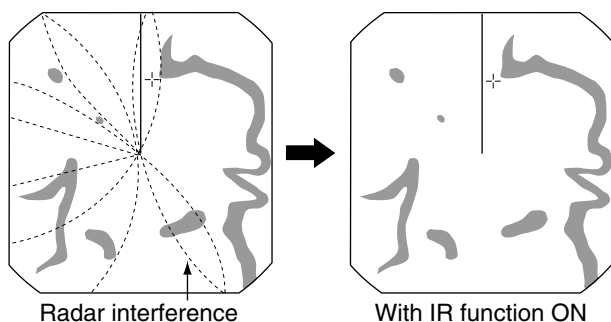

Radar interference may appear when another ship's radar is operating on the same frequency band in close proximity. The IR function can eliminate this type of interference. (p. 6)

- ① Push [MENU]/[菜单] to call up VIDEO menu.
- ② Push [▼] until the "IR" section becomes highlighted.
- ③ Push [◀ ▶] to select IR function 1, 2 or OFF.
  - "IR" appears in the upper right of the screen, when the function is activated.

## ■ STRETCH function

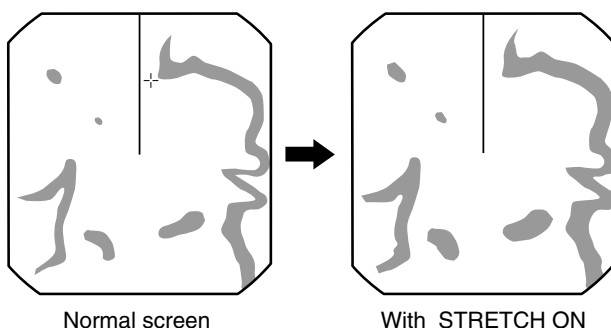

The blips can be magnified electronically for easier viewing of small targets. (p. 6)

- ① Push [MENU]/[菜单] to open the VIDEO menu.
- ② Push [▼] to select "STRETCH", then push [▶] to turn the function ON.

**NOTE:** Turn OFF this function during normal operation.

## ■ ZOOM function

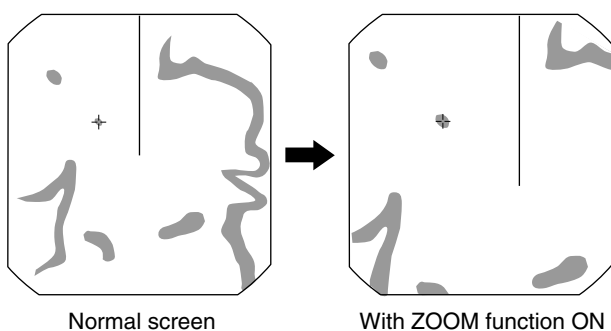

The ZOOM function expands the target to two times normal size.

• This function is available up to a 24 NM range or shorter except  $\frac{1}{8}$  NM.

- ① Push [▲ ▼ ◀ ▶] to move the cursor to the desired target.
- ② Push [TARGET]/[标记] and [TRAILS]/[尾迹显示] simultaneously to toggle the ZOOM function ON and OFF.
  - "ZOOM" appears in the lower right of the screen.

## ■ TRAILS function

The trails function memorizes echoes continuously or at constant intervals. This is useful for watching other ships' tracks, approx. relative speed, etc.

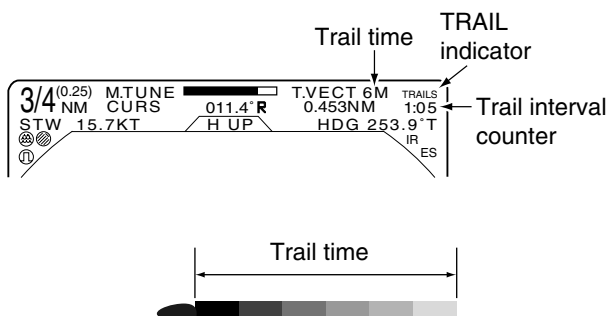

### • Setting the trail interval time

- ① Push [MENU]/[菜单] to call up the VIDEO menu.
  - Push [▼] several times until the “TRAIL TIME” section becomes highlighted.
- ② Push [◀ ▶] to select trail interval time.
  - 6 sec., 15 sec., 30 sec., 1 min., 3 min., 6 min., 15 min. and ∞ (continuous) are available.
- ③ Push [MENU] several times to exit the menu.

### • Using the TRAILS function

- ① Push [TRAILS]/[尾迹显示] to turn the trail function ON.
  - “TRAILS” and trail interval time appears in the upper right of the screen.
  - Trail interval counter starts to count up to the trail time.
- ② All displayed echoes at the plotted time are memorized and displayed with a graduated intensity together with the current echoes.
  - Echoes are displayed with minimum intensity when “∞” is selected.
- ③ Push [TRAILS]/[尾迹显示] to cancel the trail function and erase the plotted echoes.
  - “TRAILS” and trail interval time disappears.

## ■ Power save function

The power save function conserves the boat's battery power by pausing the transmission. The standby (pausing) times are selectable (rotation number is fixed to 10).

For example, when 1 min. is selected, the scanner rotates 10 revolutions; then stops for 1 min., and then repeats this sequence while the power save function is activated.

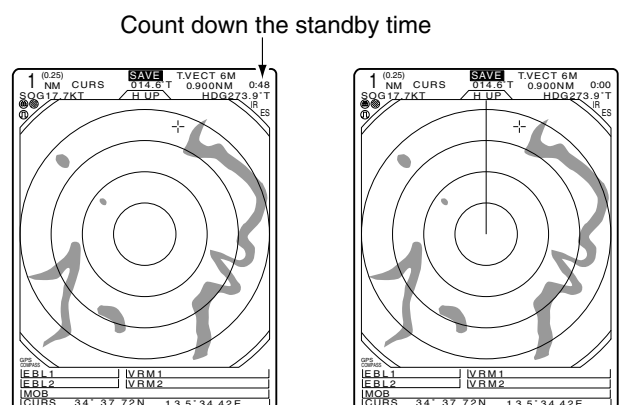

Push and hold [TX] for 1 sec. to turn the SAVE function on.

Scan and STBY alternates

### ◇ Setting the scanning standby time

- ① Push [MENU]/[菜单] four times to call up the INT. SETTING menu.
- ② Push [▼] until the “SAVE TIME” section becomes highlighted.
- ③ Push [◀ ▶] to select standby time.
  - 1, 6, 15, and 30 min. are available.
- ④ Push [MENU]/[菜单] twice to exit the menu display.

### ◇ Using the power save function

- ① Push and hold [TX (SAVE)]/[发射(节电)] for 1 sec. to turn the power save function ON.
  - The save indicator appears in the top of the screen.
- ② After the scanning rotations are finished, transmission and rotation are suspended until the selected standby time elapses.
  - The display shows the last scanned echoes until the scanning restarts.
  - “SAVE” and standby time appear in the top of the screen and the standby time is counted down.
- ③ After the selected standby time elapses, transmission and rotation restart.
- ④ Push [TX (SAVE)]/[发射(节电)] to cancel the power save function.
  - The save indicator turns OFF.

**NOTE:** When you use the power save function together with the alarm function, the CRT display is turned OFF until an object enters the programmed alarm zone, therefore, more power saving is possible. (p. 17)



## ■ Ship speed indication

When the ship speed data with NMEA 0183 format is applied, the radar can display the ship speed. Knots (KT) or kilometers/hour (KM/h) are automatically selected in the normal screen (p. 4) by selecting nautical miles (NM) or kilometers (KM) respectively.

- ① Push [MENU]/[菜单] several times to call up the FUNCTION menu.
- ② Push [▼] until the "DIST UNIT" section becomes highlighted.
- ③ Push [◀ ▶] to turn the ship speed indication to NM or KM.
- ④ Push [MENU]/[菜单] several times to exit the menu display or push [▼] once to proceed to the position display setting.

## ■ Position indication

When latitude/longitude data with NMEA 0183 format is applied, the radar can display the latitude and longitude of your ship's or cursor position in the bottom of the display. (To display the CURSOR position, bearing data is necessary.) (p. 39)

- ① Push [MENU]/[菜单] several times to call up the FUNCTION menu.
- ② Push [▼] until "POSN DISP" section becomes highlighted.
- ③ Push [◀ ▶] to select the ship position or cursor position.
- ④ Push [MENU] several times to exit the menu.

## ■ Waypoint indication

When waypoint data received from navigation equipment with NMEA 0183 format is applied, the radar can display the waypoint. To display the waypoint marker, bearing data is necessary. (p. 39)

- ① Push [MENU]/[菜单] several times to call up the FUNCTION menu.
- ② Push [▼] until the "WPT" section becomes highlighted.
- ③ Push [◀ ▶] to turn the waypoint indication ON or OFF.
- ④ Push [MENU]/[菜单] several times to exit the menu display.

## ■ Long pulse function

To magnify the blips for easier viewing of small targets, the long pulse and echo stretch (p. 11) functions are available. When the long pulse is used in the  $\frac{3}{4}$  to 2 NM range, this function magnifies target echoes to the backward direction of the target.

### • Pulse selection

- ① Push [MENU]/[菜单] several times to call up the VIDEO menu. (p. 6)
- ② Push [▼] until the "PULSE" section becomes highlighted.
- ③ Push [▶] to select the long pulse.
- ④ Long Pulse indication "Ⓜ" appears in the upper left of the screen.
- ⑤ Push [MENU]/[菜单] several times to exit the menu.

**NOTE:** Turn SP (Short Pulse) this function during normal operation. This function reduces the target distance resolution. (p. 23)

## ■ Bearing setting

The radar bearing interface accepts NMEA, N+1 or AUX data format and the bearing can use a magnetic or true north type. When a true north type bearing is used, the variation from magnetic north, etc., can be adjusted on 0.1° steps.

### ◇ Setting the bearing type

- ① Push [MENU]/[菜单] several times to call up the FUNCTION menu.
- ② Push [▼] until the "BRG" section becomes highlighted.
- ③ Push [◀ ▶] to select magnetic or true north type.
  - All displayed bearing readouts show the selected bearing type.

### ◇ Setting the magnetic variation

- ① Push [MENU]/[菜单] several times to call up the INT. SETTING menu.
- ② Push [▼] until the "MAG VAR" sections becomes highlighted.
- ③ Push [◀ ▶] to select an AUTO\* or MANUAL variation.
- ④ When a MANUAL variation is selected, push [▼], then push [◀ ▶] to set the bearing variation.
- ⑤ Push [MENU]/[菜单] to exit the menu display or push [▼] once to proceed to the bearing input setting.

\*NOTE: NMEA data is required for auto variation. **NEVER** select "AUTO" variation without NMEA data, incorrect variation data may entered.

## Distance measurement

TYPE	DESCRIPTION
RING	Displays fixed rings. Suitable for rough estimations from your own ship to any target.
VRM1	Displays a variable range marker and activated by the [▲ ▼] for the range marker selector. Suitable for accurate measurements from your own ship to a target.
VRM2	Normally functions the same as VRM1. When the VRM1 and EBL1 selects a target, the center of VRM2 appears at the intersection point. Suitable for accurate measurements from target to target.

Two measurement procedures are available with this radar. Operating them separately or jointly is possible.

The distance unit, nautical miles (NM) or kilometers (KM) is selected in the FUNCTION menu (p. 6).

### Using the fixed rings

Ring range readout

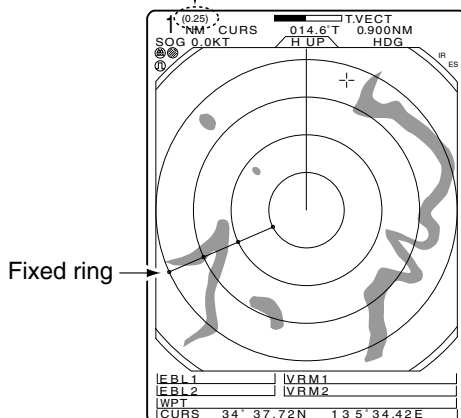

- ① Push [MENU]/[菜单] several times to call up the FUNCTION menu.
- ② Push [▼] until the “RING” section becomes highlighted.
- ③ Push [▶] to select RING function ON and display the fixed ring.
  - The interval range appears on the right of the screen range readout.
  - The ring range is fixed depending on the screen range. (See below.)
- ④ Push [MENU]/[菜单] several times to exit the menu.
- ⑤ To clear the fixed rings, push [◀] to select OFF in step ③ above.

Range (nm)	1/8	1/4	1/2	3/4	1	1.5	2	3	4	6	8	12	16	24	32	36	48*	64 <sup>†</sup>	72 <sup>†</sup>
Ring (nm)	1/20	1/20	1/10	1/4	1/4	1/4	1/2	1/2	1	1	2	2	4	4	8	6	8	16	12
	2	5	5	3	4	6	4	6	4	6	4	6	4	6	4	6	6	4	6

**NOTE:** When the screen is shifted, the number of rings may differ.  
\*Available for the MR-1000TII/TIII. †Available for the MR-1000TIII only.

### Using the variable range marker

- ① Push [EBL1 (VRM1)]/[方位线1(距标1)] to display the VRM1 and EBL1; then, push [▲ ▼] to set the marker.
  - The range between the ship and the target is indicated in the VRM readouts.
- ② Push [EBL2 (VRM2)]/[方位线2(距标2)] to display the VRM2 and EBL2; then, push [▲ ▼] to set the marker.
  - The range between the ship and the target is indicated in the VRM readouts.
  - When the VRM1 and EBL1 are displayed, the center of VRM2 appears at the intersection point of the VRM1 and EBL1.
  - The VRM2 disappears when [EBL1 (VRM1)] is pushed.
- ③ Push [EBL1 (VRM1)]/[方位线1(距标1)] to exit the menu display.

## ■ Bearing and Distance measurement

### ◇ Using the EBL and VRM

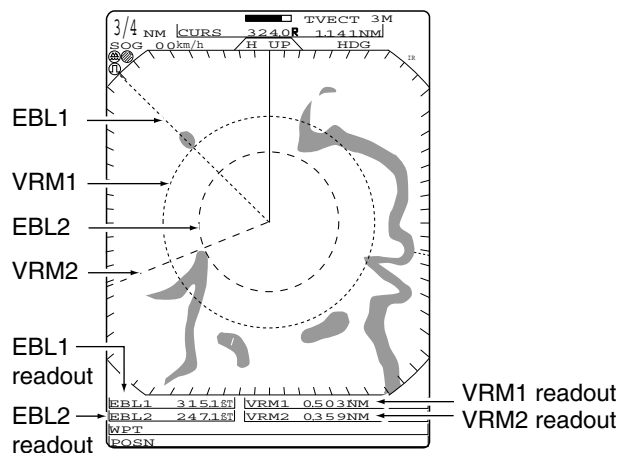

This radar has 2 Electronic Bearing Lines (EBL) to indicate the target direction from your ship or a target.

- ① Push [**▲ ▼ ◀ ▶**] to move the cursor on the desired target.
- ② Push [EBL1 (VRM1)]/[方位线1(距标1)] to display the EBL1 and VRM1.
  - Push [**◀ ▶**] to rotate the electronic bearing line.
  - Push [**▶**] to rotate clockwise and push [**◀**] to rotate counterclockwise.
  - Push [**▲ ▼**] to increase or decrease the variable range marker ring size.
  - The EBL1 and VRM1 readouts indicate the target bearing and distance.
  - The EBL readouts indicate the target bearing;
    - 0 to 360°R : Relative direction, when '360°R' is selected in the EBL/PI of the FUNCTION menu. (see p. 6)
    - P/S 0 to 180° : Bow direction, when 'PT/SB' is selected in the EBL/PI of the FUNCTION menu. (see p. 6)
    - 0 to 360°T\* : True or magnetic bearing, when selecting 'TRUE' in the EBL/PI of the FUNCTION menu. (see p. 6)
- \*Bearing data is required. (p. 39)
- ③ Push [EBL1 (VRM1)]/[方位线1(距标1)] to clear the EBL1 and VRM1.
  - Cursor remains on the display.
- ④ Push [**▲ ▼ ◀ ▶**] to move the cursor on the desired target.
- ⑤ Push [EBL2 (VRM2)]/[方位线2(距标2)] to display the EBL2 and VRM2 on the display.
  - When the EBL1 and VRM1 are displayed, the beginning of EBL2 and VRM2 appears at the intersection point of the EBL1 and VRM1.
  - The EBL2 and VRM2 disappears when [EBL1 (VRM1)]/[方位线1(距标1)] is pushed.
- ⑥ To clear the EBL1 and VRM1, push [EBL1 (VRM1)]/[方位线1(距标1)].

## Advanced measurements

### Measuring the distance and direction between 2 targets

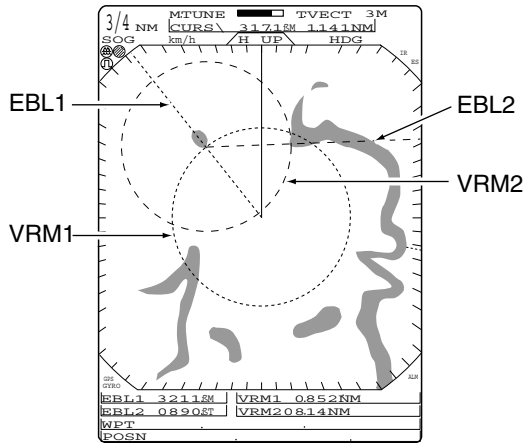

Using both Electronic Bearing Lines (EBL) and both Variable Range Markers (VRM), the following advanced measurements can be made:

- ① Push [▲ ▼ ◀ ▶] to move the cursor on the desired target.
- ② Push [EBL1 (VRM1)]/[方位线1(距标1)] to display the EBL1 and VRM1.
  - Push [◀ ▶] to rotate the electronic bearing line.
  - Push [▲ ▼] to increase or decrease the variable range marker ring size.
- ③ Push [EBL2 (VRM2)]/[方位线2(距标2)] to display the EBL2 and VRM2.
  - The intersection of the EBL1 and VRM1 becomes the center of the EBL2 and VRM2.
- ④ Push [▲ ▼ ◀ ▶] to move the cursor on the other target.
  - Push [◀ ▶] to rotate the electronic bearing line.
  - Push [▲ ▼] to increase or decrease the variable range marker ring size.
- ⑤ The VRM2 readout shows the distance between the two targets. The EBL2 readout shows the direction from one target to the other.

### Measuring the relative speed and course of a target

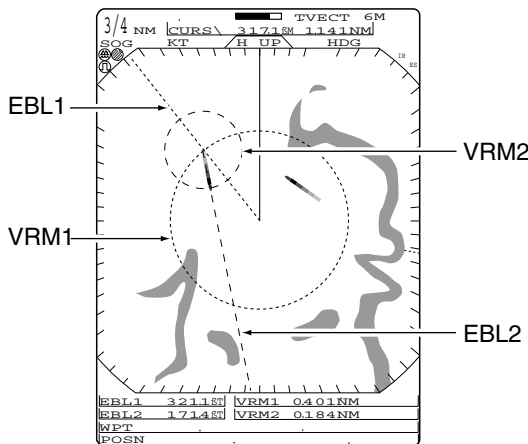

- ① Push [TRAILS]/[尾迹显示] (p. 12) ON; then wait until the trail time count up reaches to the TRAIL TIME.
- ② Set VRM1 and EBL1 to a previously plotted target as described above.
- ③ Set VRM2 and EBL2 to the current plotted position of the same target as described as above.
- ④ The VRM2 readout is a measure of target movement which can be converted into relative target speed.
  - For example, when a 6 min. trail time is selected, multiplying the distance by ten gives the relative average speed of the target.
  - If your ship is stationary during the plotting time, the converted speed and direction become absolute.
  - The converted speed unit is knots or kilometers/hour when the selected speed unit in the FUNCTION menu is nautical miles (NM) or kilometers (KM), respectively.
- ⑤ The EBL2 readout shows the course direction of the target.

### Measuring the distance and course from a waypoint

- ① Display a waypoint. (see p. 13)
- ② Set VRM1 and EBL1 to the displayed waypoint targets as described above.
- ③ Set VRM2 and EBL2 to a target (e.g. the next waypoint) as described above.
- ④ The VRM2 readout shows the distance to the target from the waypoint.
  - The distance unit can be selected as nautical miles (NM) or kilometers (KM) in the FUNCTION menu.
- ⑤ The EBL2 readout shows the direction to the target from the waypoint.

The unit has an alarm function to protect your ship from collisions. If other ships or islands, etc. come into the pre-programmed alarm zone, the function alerts you with an alarm. You can set the desired range and bearing for an alarm zone. While the alarm function is activated, the power save function turns the CRT OFF until an alarm is given, to conserve power.

## Alarm zone setting

### ◇ Setting and using the alarm function

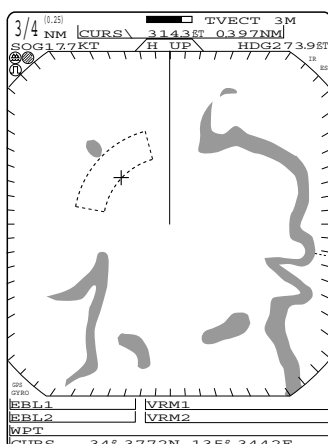

Fig. 1

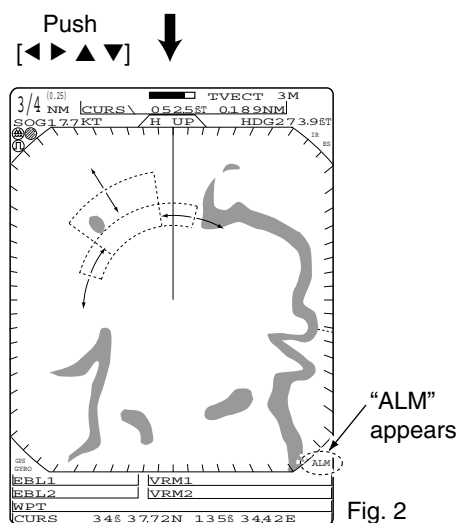

Fig. 2

- ① Push [+]/[量程+] or [-]/[量程-] to select the desired range.
- ② Push [◀ ▶ ▲ ▼] to set the cursor to the starting point of the alarm zone.
- ③ Push and hold [ALM]/[报警] for 1 sec. to enter the alarm zone setting.
  - The starting zone appears on the screen. (Fig. 1)
- ④ Push [◀ ▶] to adjust an angle and push [▲ ▼] to set the distance of the alarm zone.
  - The selected alarm zone appears.
- ⑤ Push [ALM]/[报警] to fix the alarm zone and activate the alarm function.
  - “ALM” appears on the bottom of the screen.
  - The selected alarm zone remains.
- ⑥ If a target comes into or goes out of the alarm zone, an alarm beep is emitted.
  - Push [ALM]/[报警] to cancel the alarm signal and function .
- ⑦ To deactivate the alarm function, push [ALM]/[报警].
  - “ALM” and alarm zone disappear from the screen.
- ⑧ To activate the alarm function again with the same programmed zone, push [ALM]/[报警].
  - “ALM” and pre-programmed alarm zone appears. (Fig. 2)

### • Using the function with power saver

To activate the power save function, push and hold [TX (SAVE)]/[发射(节电)] for 1 sec. while the alarm function is turned ON.

- The CRT display turns OFF.
- When a target comes into the alarm zone, an alarm signal is emitted, the CRT display turns ON and the power save function is cancelled.

## Zone alarm setting

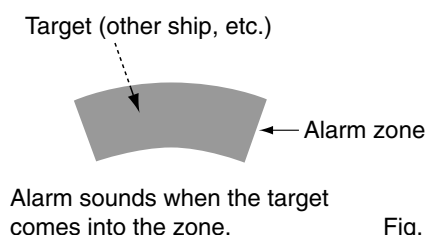

Fig. 3

Zone alarm beep is emitted when the target comes into the zone, or the target goes out of the zone. (p. 6)

- ① Push [MENU]/[菜单] several times to call up the FUNCTION menu.
- ② Push [▼] until the “ZONE ALARM” section becomes highlighted.
- ③ Push [◀ ▶] to select IN or OUT
  - IN : Alarm sounds when the target comes into the zone. (see Fig. 3)
  - OUT: Alarm sounds when the target goes out of the zone.

## ■ ATA (Automatic Tracking Aid)

By tracking automatically the target chosen by the cursor key, the closest point of approach (CPA) and the time to closest point of approach (TCPA) limit of a own ship and a target are calculated.

ATA is the function to tell about to alarm sound, when both CPA and TCPA becomes below a setting value (the approach watch area).

The range of the target which can be registered is taken as a target with a highest luminosity level of 0.2–16 miles.

- Max. 10 targets can be plotted on the screen.
- Plot positions shall be identified by an approved symbol mark (p. 20) and associated plot number.
- The vector origin will move across the screen at a rate and direction defined by the calculated true or relative course and speed.
- The vector will be displayed on the target.
- Display accuracy may increase by the self-ship and course change of target or acceleration, slowdown, etc.

## ■ ATA menu setting

A T A M E N U			
ATA	OFF	ON	
No.DISP	OFF	SEL	ALL
VECT	TRUE	REL	
OWN VECT	OFF	ON	
ALARM	OFF	ON	
CPA LIMIT	1.0NM		
TCPA LIMIT	1 MIN		

Set the ATA menu items before using the ATA function.

- ① Push [MENU]/[菜单] several times to turn the ATA menu ON.
- ② Push [▶] to turn the ATA function ON.
- ③ Push [▼] to select the “No. DISP” to select the target identification number type which appears at the right side of the mark. Push [◀▶] to select the appropriate type.
  - OFF: No number appears.
  - SEL: Number appears by the selected mark only.
  - ALL: All numbers appear by the marks.
- ④ Push [▼] to select “VECT”; push [◀▶] to select the vector type.
  - TRUE (True vector):  
The predicted true motion of a target as the result of your own ship’s direction and speed input.
  - REL (Relative vector):  
The predicted movement of a target relative to your own ship.
- ⑤ Push [▼] to select “OWN VECT”; push [◀▶] to turn the own vect function ON or OFF.
  - OFF: For not displaying the own ship vector.
  - ON: To display your own ship’s vector.
- ⑥ Push [▼] to select “ALARM”; push [◀▶] to turn the alarm function ON or OFF.
  - ATA alarm is emitted when both CPA and TCPA reaches the limit.
- ⑦ Push [▼] to select the “CPA\* LIMIT”; push [◀▶] to set the CPA limit distance.
- ⑧ Push [▼] to select the “TCPA\* LIMIT”. Push [◀▶] to set the TCPA limit time.

\*CPA/TCPA: Closest Point of Approach and Time to Closest Point of Approach limit is defined by the observer to a given warning when a target or targets are close to within those limits from your own ship.

- ⑨ Push [MENU]/[菜单] to exit the ATA menu.

## ■ ATA operation

NEW	BRG	DIST
	CSE	SPD
	CPA	TCPA

Identification No.	Bearing	Course	Distance	Speed
NO. 10	BRG 305.7T	DIST 11.43NM		
	CSE 081.3T	SPD 12.3KT		
0:20	CPA 5.9NM	TCPA 0:50		

Closest Point of Approach

Time to Closest Point of Approach

Passage of time

Select the target which you want to track on the display.

- ① Push [▲ ▼ ◀ ▶] to move the “+” cursor on the desired target.
- ② Push [TARGET]/[标记] for 1 sec. to select the target for tracking.
  - Dotted square symbol appears on the cursor.
  - Target identification number, bearing, distance readout, course (CSE), speed (SPD), CPA and TCPA appear in the information screen.
  - Timer starts to count the progressing time.
  - The vector appears on the target, after the progressing time of 20 sec. has passed.
  - It changes to the circle display of a solid line and a vector display, and tracking operation is decided, after the progressing time of one min. has passed.
  - When the target which is following disappears, a mark changes to a lozenge and is blinked. A mark disappears after one min..
  - When a target advances within a setting value, a mark changes to a triangle, blinks and sounds alarm sound. Alarm sound will be cancelled if one of key is pushed.
  - To cancel the target setting, move the cursor on the target, then push [TARGET]/[标记] for 1 sec.
  - [TARGET]/[标记] is pushed for changing the display of EBL/VRM etc. to target information.
  - In order to choose target which displays information, cursor is united with target and [TARGET]/[标记] is pushed.

## ■ Plotting marks

There are 5 kinds of plotting marks.

- : Selected, uncalculated mark.
- : Selected, calculated mark.
- : Normal, calculated mark.
- ⚠ : CPA/TCPA alarm mark. The target is close to within a minimum range and time. Alarm emit indicator. Push [TARGET]/[标记] to cancel the alarm.
- ◇ : When the tracking of a target disappears.

## ■ Course and speed vector

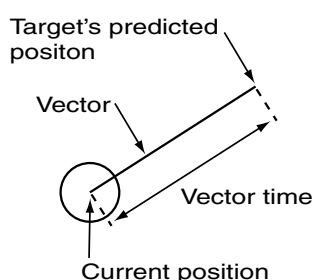

The vector indicates the target's predicted, true or relative course and speed.

- Vector time may change depending on the TRAIL TIME setting. (see VIDEO menu, p. 6)
- The tip of the vector shows the target's predicted position after a certain time, which has been selected in the “TRAIL TIME”.

## ■ Plots

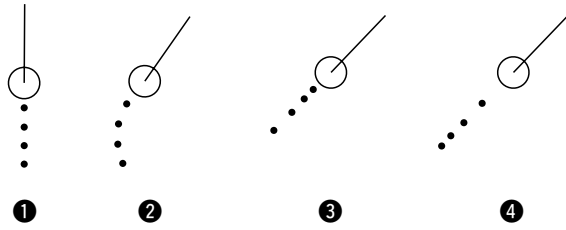

Plot displays past position of targets every 1 min. as 3 dots.

- ① Target goes straight.
- ② Target turns right.
- ③ Target reduces speed.
- ④ Target increases speed.



Radar uses a form of electromagnetic radiation, which like light, can be reflected. Because of this property, some objects may cause false echoes on the screen where in fact no targets actually exist. These echoes may appear if a large vessel, bridge, or tank is in proximity. Operators should be familiar with the effects of these phenomena. In some cases, echoes can be reduced.

## ■ Side-lobe echoes

Radiation can escape on each side of the beam inside the lobes. If a target reflects this radiation, it will be displayed on the screen as an echo.

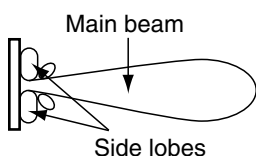

Side-lobe echoes usually occur at short ranges and as a result of large (strongly reflective) targets. They can be reduced with proper adjustment of the [SEA]/[海浪抑制] control.

See p. 10 for the [SEA]/[海浪抑制] control.

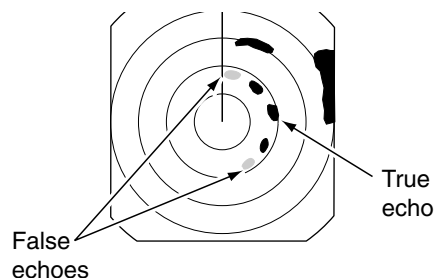

## ■ Indirect echoes

Indirect echoes may be returned from either a passing ship, or returned from a reflecting surface, such as a mast on your own ship.

An indirect echo from a reflecting surface will appear on a different bearing from the direct (true) echo, but the distance will be approximately the same for both.

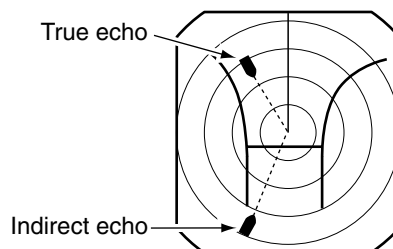
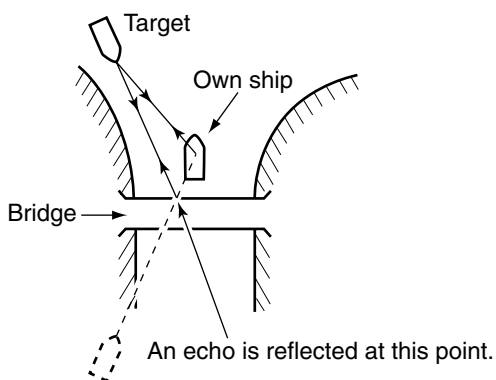
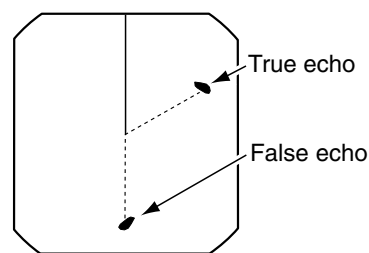
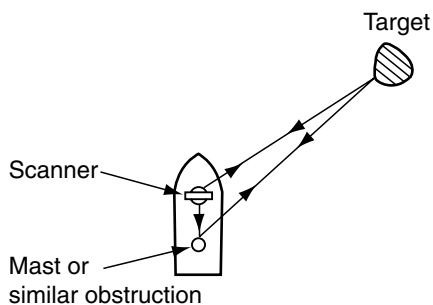

### Multiple echoes

Multiple echoes may appear when a short-range and strong echo is received from a ship, bridge, or break-water.

Multiple echoes will appear beyond the target's true echo point on the same bearing of a large target. They can be reduced with proper adjustment of the [SEA]/[海浪抑制] control. See p. 10 for the [SEA]/[海浪抑制] control.

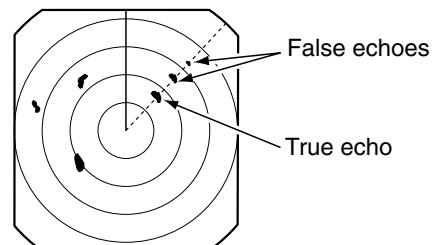
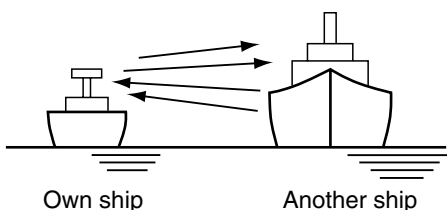

### Minimum range

Detection at short range is very important. Minimum range is determined primarily by transmitter pulse length, vertical beam width and height of the scanner unit. The shorter the transmission time, the quicker the return echoes can be received and their distance measured.

The ability to see targets very close to the ship is decreased if the scanner is mounted too high off the water, because the bottom of the vertical beam of the scanner cuts off nearby targets.

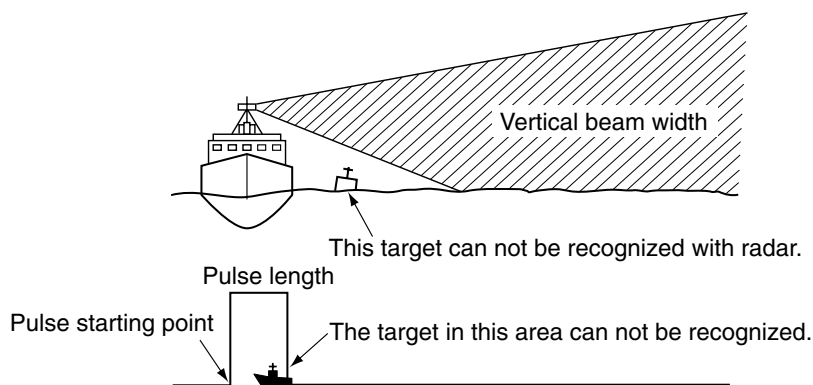

## Blind and Shadow sectors

Blind or Shadow sectors may exist because of obstructions such as masts, derricks or stacks. An obstruction may throw either a complete or partial shadow as shown in the diagram below. If a target is in a shadow sector, target echoes may not appear on the screen.

Shadow sector

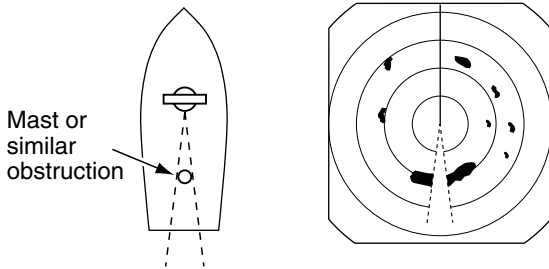

When tall and massive targets such as a large island are located at close range also shadowed without producing any echoes. This phenomenon is called blind sector. It is very important to know the bearings and widths of all shadow sectors caused by your own ship's obstructions.

Blind sector

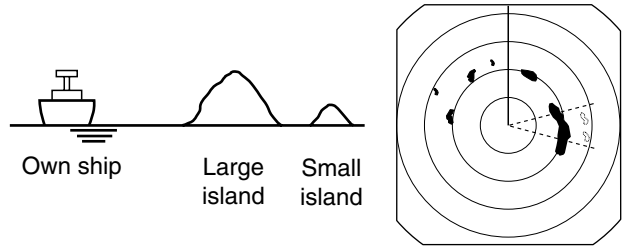

## Target resolution

Target resolution is determined by the horizontal beam width and transmit pulse width. Sometimes it is difficult to detect two targets which are separated by short distances or which are in the same direction.

### Distance resolution

When two targets are separated by more than the pulse width, they appear as two echoes.

When two targets are not separated by more than the pulse width, they appear as 1 echo.

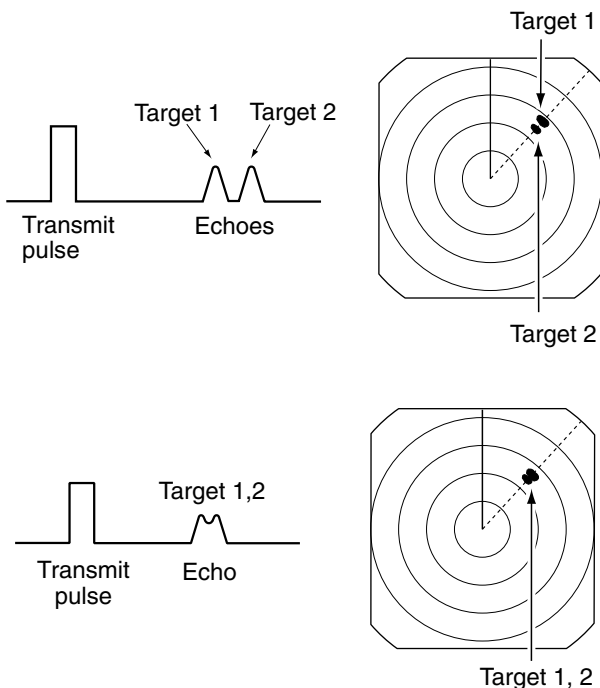

### Direction resolution

When two targets are separated by more than the horizontal beam width, they appear as two echoes.

When two targets are not separated by more than the horizontal beam width, they appear as one echo.

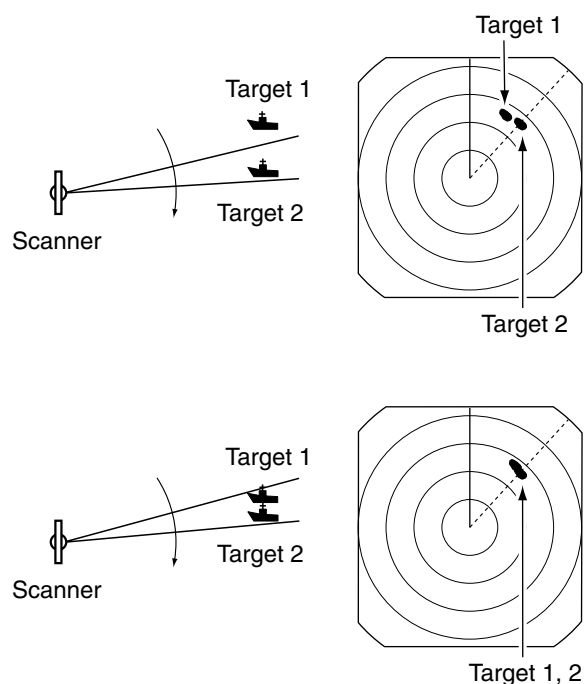

## ■ Connecting the units

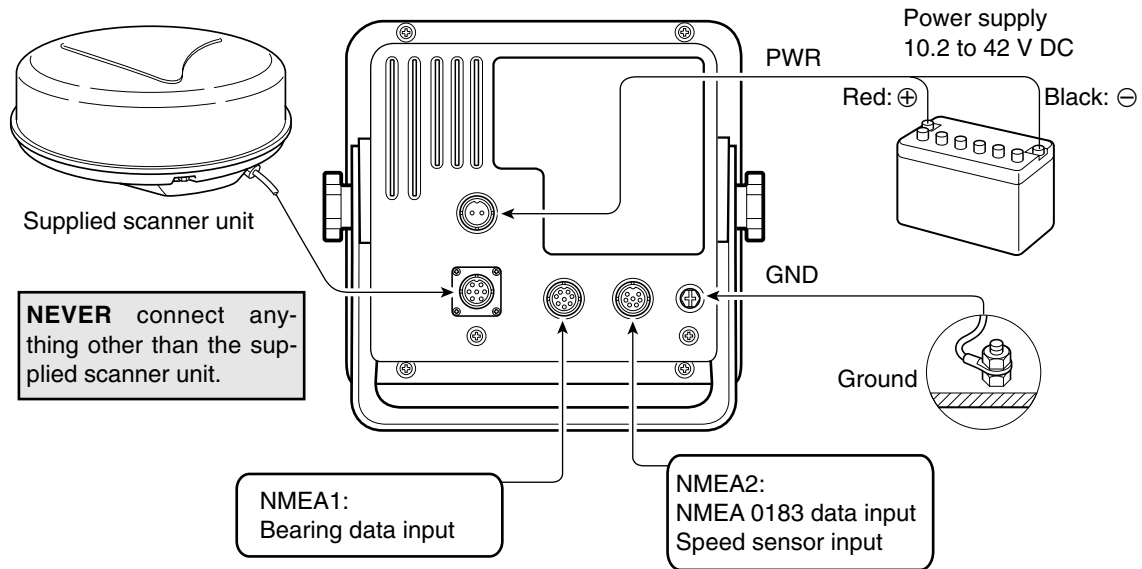

### NMEA1 connection

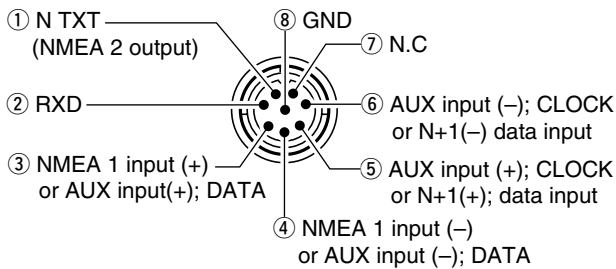

### NMEA2 connection

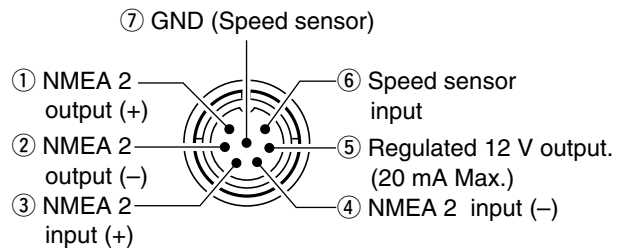

## ■ Power source requirement

### ◇ DC power source

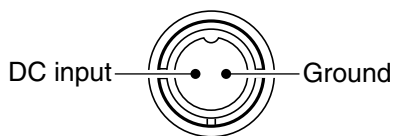

**CAUTION:** Incorrect cable connection may damage the radar.

The radar is designed for connection to any power source if the voltage is 10.2–42 V DC, so that a 12, 24, or 32 V DC battery can be used without a DC-DC converter, or any internal modifications.

### • DC power cable connection

Connect the supplied DC power cable as shown in the diagram.

## ■ Ground connection

To prevent electrical shocks and other problems, ground the display unit through the [GND] terminal on the unit's rear panel. For best results, connect a heavy gauge wire or strap to the nearest grounding point on the boat. The distance between the [GND] terminal and the ground point should be as short as possible.

## ■ Installing the display unit

### ◇ Location

Select a place for installation which meets the following important conditions:

- ① The display unit should be placed near the wheel in the cabin so that an operator may easily view the radar screen while facing the bow.
- ② To minimize interference, **KEEP** the unit **AT LEAST THE COMPASS SAFE DISTANCE** stated in the serial No. seal on the rear panel away from the compass and navigation receiver.
- ③ Select a position where there is no danger of salt or fresh water spray or immersion.
- ④ Select a location where it is easy to perform maintenance or adjustment after installation.
- ⑤ Select a location which can support the weight of the display unit.
- ⑥ **DO NOT** select areas subject to extreme heat, cold, vibrations or direct sunlight.

### •SX-2713/2779 Mounting Bracket

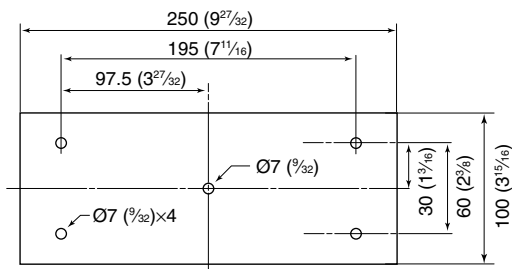

Fig. 1

### ◇ Mounting

The mounting bracket supplied with the display unit allows “dashboard” or “overhead” mounting.

- ① Hold the mounting bracket up to the selected location and mark pilot holes for the 5 installation holes using the template.
  - The template is provide on p.41.
- ② Drill 5 holes of 3 mm (1/8 in) in diameter as shown in the diagram. (Fig. 1)
- ③ Install the bracket using the screws, nuts, bolts or washers, with the supplied accessories. (Fig. 2)
- ④ Adjust the display unit to an adequate view angle.
- ⑤ Install the supplied viewing hood.

### •Mounting Bracket installation

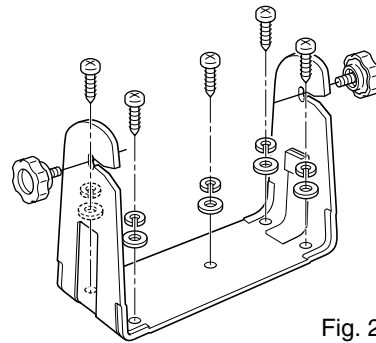
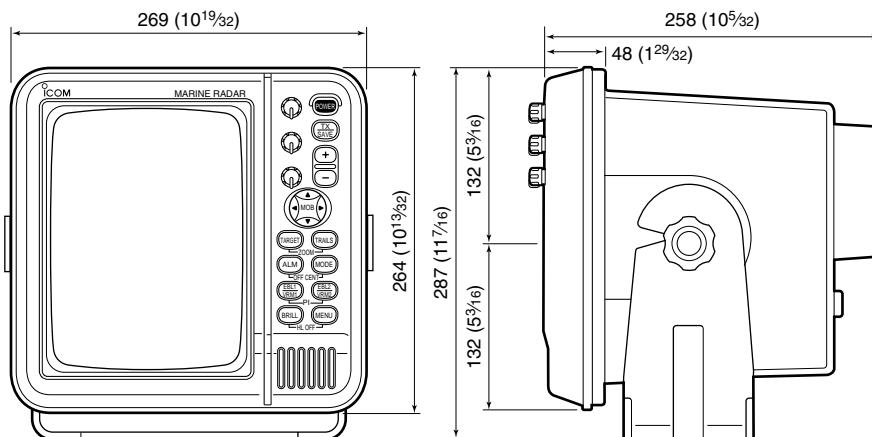
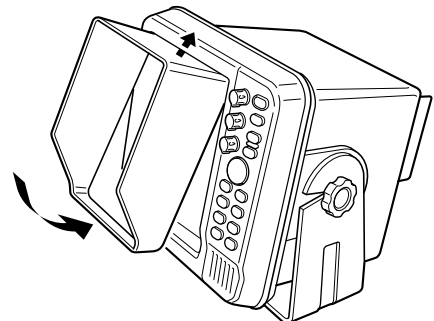

Fig. 2

### •SX-2713/2779



### • Viewing hood installation



## ■ Mounting the EX-2714 scanner unit

**WARNING: BE SURE [POWER] is OFF** whenever you are working with the scanner unit.

The scanner unit is designed to be weatherproof and completely watertight. Select a place for installation which meets the following important conditions.

- ① The scanner unit must be near the boat's center line and have a good view in every direction. Be sure there are no objects in the surrounding area which will intercept the scanning beam.
- ② **KEEP** the scanner unit away from any smokestacks. Smoke can damage the unit.
- ③ When the boat is equipped with a radio directional finder (RDF) system, keep the scanner unit at least 2 m (6.6 ft) away from any RDF antenna.
  - Radiation from the scanner unit can affect the measurement data of RDF equipment.
- ④ The unit should be placed as high as possible on the boat to obtain best performance with maximum range.
- ⑤ If you install two or more radar in one boat, install one above, and one below.
- ⑥ The mounting surface must be parallel with the boat's waterline.
- ⑦ If the height is insufficient to install the scanner unit, build a special frame for installation.

### ◇ Mounting

- ① Drill four holes of 12 mm (1/2 in) in diameter using the template.
- ② If the mounting surface or platform is metal, apply sealing compound around the holes to prevent corrosion and to waterproof the unit.
- ③ Fix the scanner unit to the selected position with bolts of 10 mm (3/8 in) in diameter, with flat and spring washers. The supplied bolts are two lengths: 25 mm (1 in) or 50 mm (2 in).

**CAUTION: SECURE** the four bolts tightly.

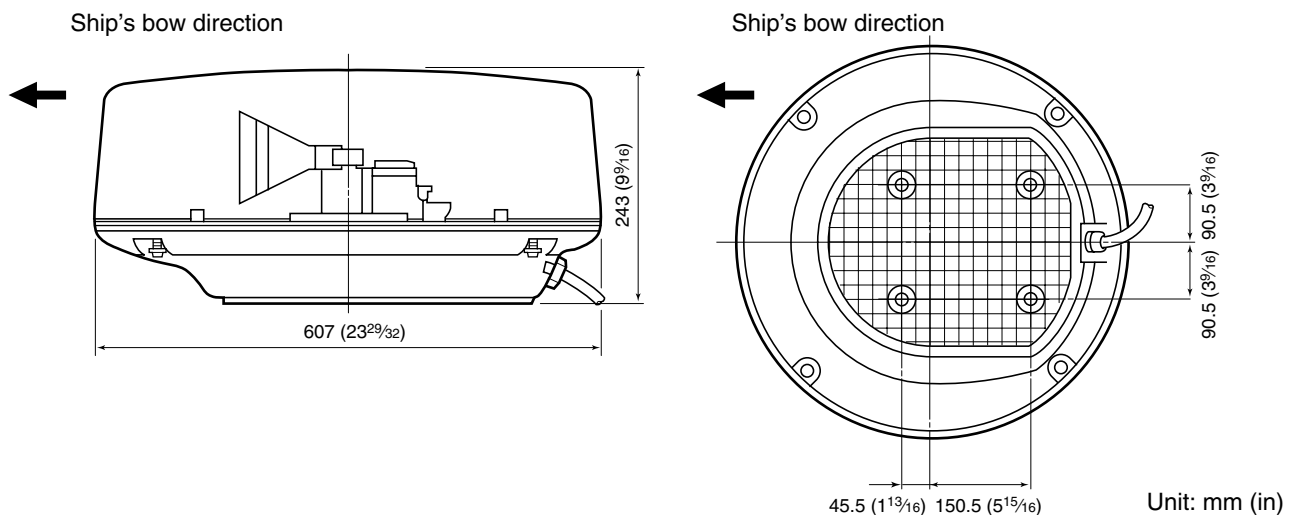

## ■ Wiring the EX-2714 system cable

**CAUTION: NEVER** cut the supplied system cable.

- ① Loosen the four bolts using a hex head wrench on the bottom of the scanner unit, and open the unit.
- ② Loosen the nut on the scanner unit and pass the system cable through the nut and sealing tube.
- ③ Insert the PA cable (black and white) connector to the PA unit connector J1. (\*1; Be sure to follow the following diagram carefully)
- ④ Connect the shielding wire to the ground plate with the screw as shown in the diagram.
- ⑤ Clamp the system cable with the ferrite bead attached near the sealing connector. Be sure to clamp it tightly.
- ⑥ Connect the power cable (black and red) end to the power unit connector. (\*2; Be sure to follow the following diagram carefully).
- ⑦ Tighten the sealing-nut, then replace the radome cover over the scanner unit.  
**DO NOT** stretch the system cable too much, otherwise miss contact of the connector may occur.
- ⑧ Tighten the four bolts on the bottom of the scanner unit.
  - The four projections around the circumference of the radome cover show the positions of the bolt receptacles.

### •Scanner unit disassembly

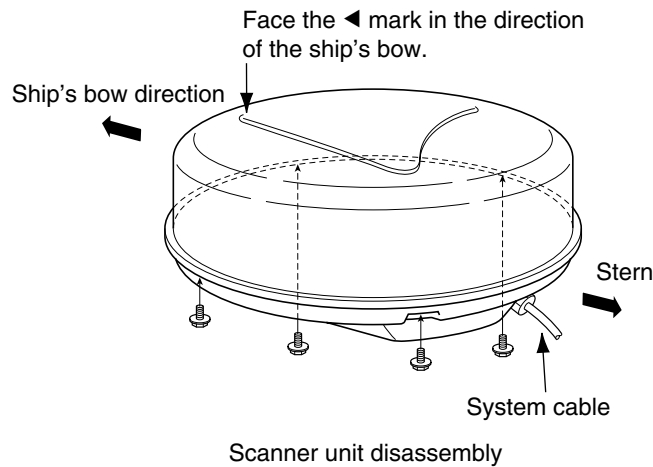

### •Connect the system cable

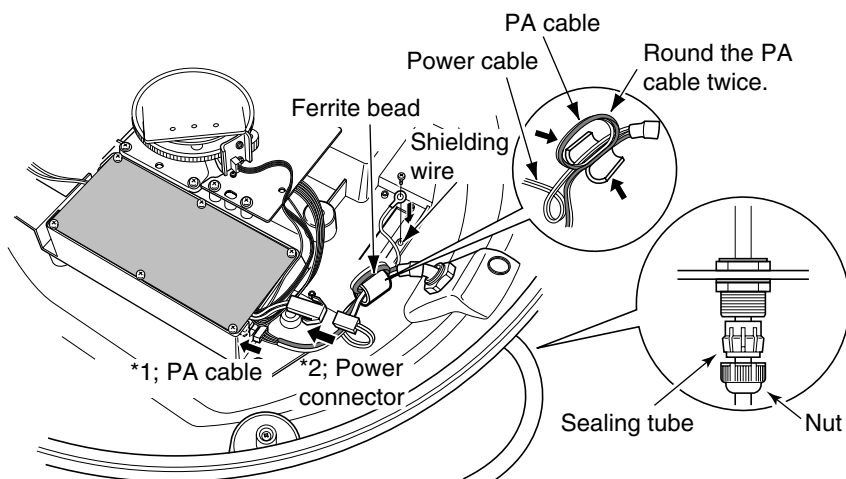

## ■ Mounting the EX-2780 scanner unit

### • Location

**WARNING: BE SURE [POWER]/[电源开关] is OFF** whenever you are working with the scanner unit.

The scanner unit is designed to be weatherproof and completely watertight. Select a place for installation which meets the following important conditions.

- ① The scanner unit must be near the boat's center line and have a good view in every direction. Be sure there are no objects in the surrounding area which will intercept the scanning beam.
- ② **KEEP** the scanner unit away from any smokestacks. Smoke can damage the unit.
- ③ When the boat is equipped with a radio directional finder (RDF) system, keep the scanner unit at least 2 m (6.6 ft) away from any RDF antenna.
  - Radiation from the scanner unit can affect the measurement data of RDF equipment.
- ④ The unit should be placed as high as possible on the boat to obtain best performance with maximum range.
- ⑤ If you install two or more radar in one boat, install one above, and one below.
- ⑥ The mounting surface must be parallel with the boat's waterline.
- ⑦ If the height is insufficient to install the scanner unit, build a special frame for installation.

### • Mounting

- ① Drill four (4) holes of 12 mm (1/2 in) in diameter using the template.
- ② If the mounting surface or platform is metal, apply sealing compound around the holes to prevent corrosion and to waterproof the unit.
- ③ Fix the scanner unit to the selected position with bolts of 10 mm (3/8 in) in diameter, with flat and spring washers. The supplied bolts are two lengths: 25 mm (1 in) or 50 mm (2 in).

**CAUTION: SECURE** the four bolts tightly.

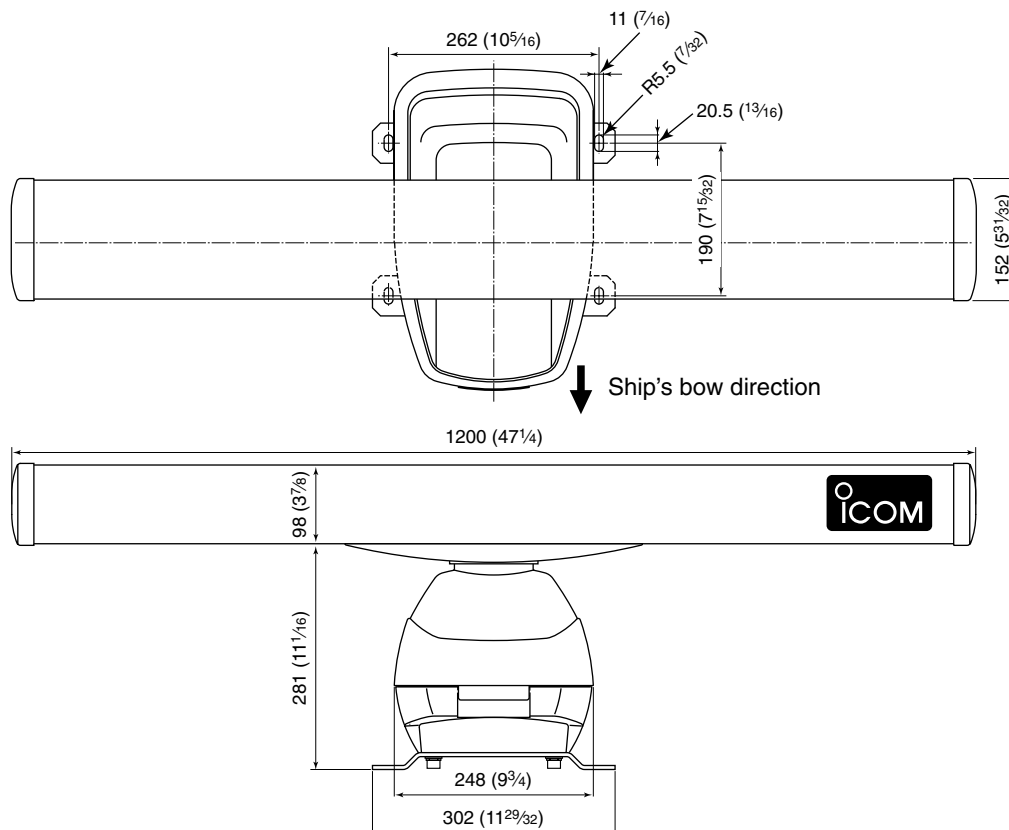
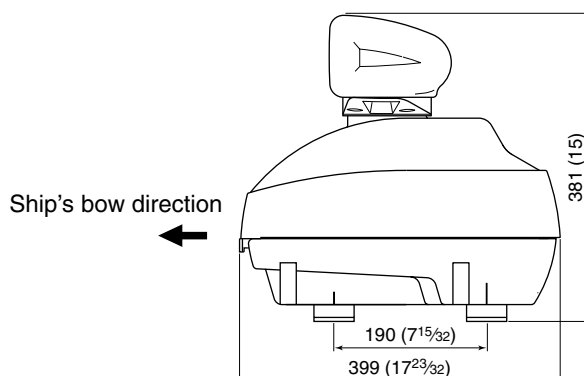



## ■ Wiring the EX-2780 system cable

**CAUTION: NEVER** cut the supplied system cable.

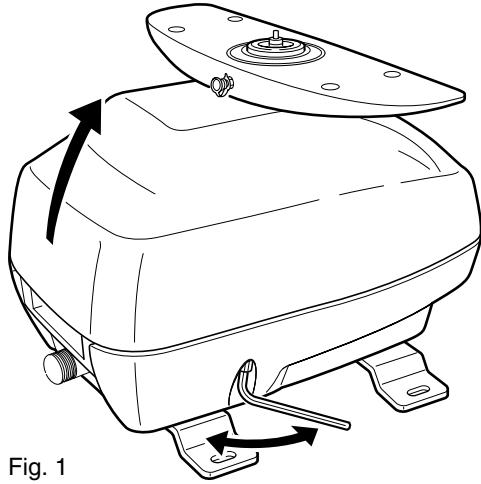

Fig. 1

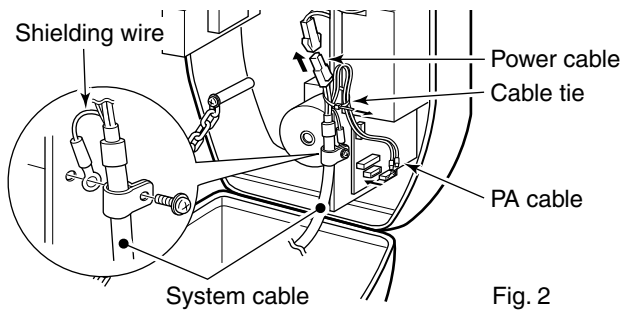

Fig. 2

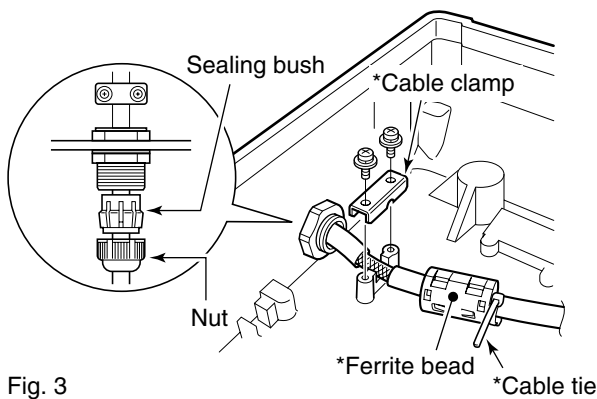

Fig. 3

- ① Loosen the four bolts using the supplied hex head wrench on the bottom of the scanner unit, and open the unit. (Fig. 1)
- ② Loosen the nut on the scanner unit and pass the system cable through the nut and sealing tube. (Fig. 3)
- ③ Connect the power cable (black and red) end to the power unit connector through the rouped cable tie. (Fig. 2)
- ④ Insert the PA cable (black and white) connector to the PA unit connector. Be sure to follow the diagram below carefully. (Fig. 2)
- ⑤ Connect the shielding wire to the chassis with the screw as shown in the diagram. (Fig. 2)
  - Fix the PA cable with the rouped cable tie as illustrated in Fig. 2.
- ⑥ Clamp the system cable with the cable clamp metal fitting using a screw near the sealing connector. Be sure to clamp it tightly. (Fig. 3)
- ⑦ Clamp the system cable with the ferrite core attached near the sealing connector. Be sure to clamp it tightly. (Fig. 3)
  - Tighten the ferrite bead with cable tie.
- ⑧ Tighten the sealing-nut (Fig. 3), then replace the radome cover over the scanner unit. (Fig. 1)
- DO NOT** stretch the system cable too much, otherwise miss contact of the connector may occur.
- ⑨ Tighten the four bolts on the bottom of the scanner unit. (Fixing torque: 9.8 N•m)

## ■ Fixing the EX-2780 scanner unit

- ① Put the scanner unit\*<sup>1</sup> on the stay, then fix the antenna rotor with installation bolts of 8 mm (5/16 in) in diameter, with flat and dish washers and a sealing washer. Be sure to keep the direction of the dish washer correct as shown in the diagram\*<sup>2</sup>. (Fig. 4)
- ② Apply lubricant specified below or an equivalent one to the motor bearing\*<sup>3</sup>, if required.
  - Manufacture: ESSO
  - Type: BEACON 325
- ③ Connect the grounding wire to the ground plate with the supplied terminal if required. (Fig. 5)

**NOTE: When using the optional system cable.**

Peel the outer sheath of the system cable when using the optional system cable **OPC-1078A**.

• **BE CAREFUL ! DO NOT** cut the inner shield wire when peeling the outer sheath.

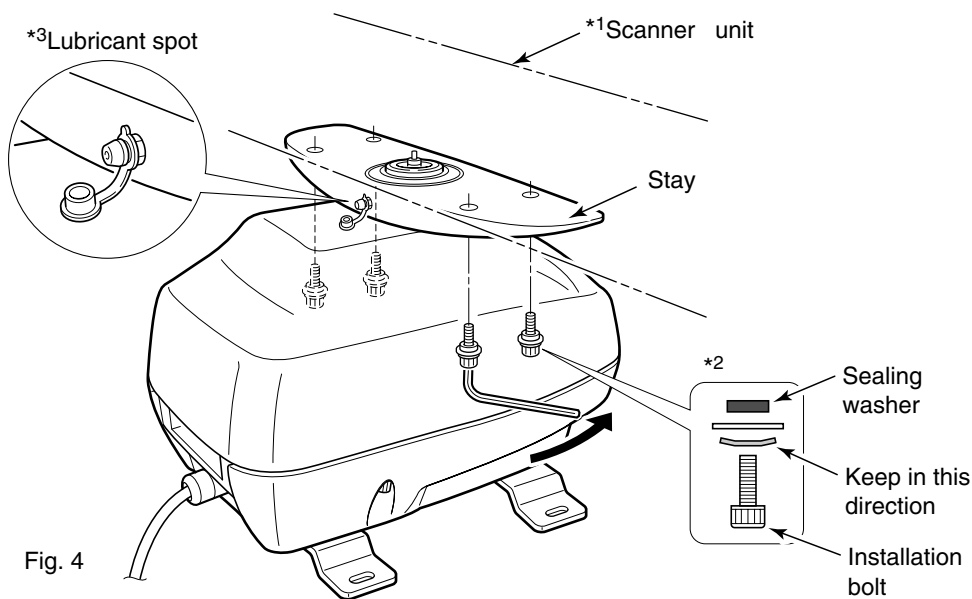
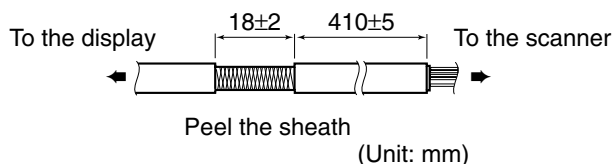

Fig. 4

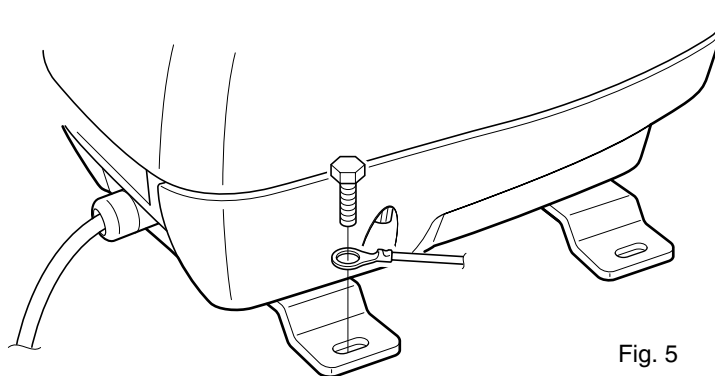

Fig. 5

**◇ Antenna rotation speed**

The antenna rotation speed can be selected from 48 rpm and 36 rpm. (Default: 48 rpm)

Pushing and holding [-]/[量程-] for 1 sec. to select 36 rpm rotation speed, pushing and holding [+]/[量程+] for 1 sec. to select 48 rpm rotation speed.

**◇ Test pattern indication**

To check the CRT indication distortion, a test pattern can be displayed.

While pushing and holding [MENU]/[菜单], turn power ON to display the test pattern.

To return to normal operating condition, turn power OFF then ON again.

**◇ Para-simulation screen**

The MR-1000RII/TII/TIII has para-simulation screen capability.

- ① While pushing and holding [BRILL]/[亮度], turn power ON.
- ② After the count down indication, stand-by screen appears.
- ③ Push [TX (SAVE)]/[发射(节电)] to display the para-simulation screen.
- ④ To return to normal operating condition, turn power OFF then ON again.

**◇ All reset**

- ① While pushing and holding [TARGET]/[标记], [EBL1 (VRM1)]/[方位线1(距标1)] and [EBL2 (VRM2)]/[方位线2(距标2)], turn power ON.
- ② Follow the guidance.

# 11 SERVICE MAN MENU

## Service man menu

**CAUTION:** The SERVICE MAN MENU is available for service purposes only. **DO NOT** change any setting on the menu, otherwise the equipment may not operate at its original performance.

To open the “SERVICE MAN” menu.

Push [MENU]/[菜单] several times to show the “SERVICE MAN” menu.

## Select the language

Menu screens can be displayed in 2 different languages.

Selectable languages; ENGLISH, 中文 (CHINESE)

After opening the “SERVICE MAN” menu;

- ① Push [▲] to show the present language.
- ② Push [◀ ▶] to select desired language, then push [▼] to continue the setting.
- ③ Push [MENU]/[菜单] to exit the “SERVICE MAN” menu.

SERVICE MAN	
中文	ENGLISH
TIMING ADJ.	OUTPUT VOLTAGE 30.0
HDG ADJ. 0.0°	HV 340
SPD ADJ. 24000	MONITOR 7.5
SETUP MEMORY RECALL	HEATER 0.55
SAVE	MG 3.0
	TX TIME
	5731.0H
RANGE	1/8 3/4 2 6 16 36 72
	1/4 1 3 8 24 48
	1/2 1.5 4 12 32 64

### ◇ TIMING ADJ.

- Corrects the distance.

### ◇ HDG ADJ.

- Adjusts the electronic heading line adjustment.

### ◇ SPD ADJ.

- Enter the pulse rate of the speed sensor.

### ◇ RANGE

- 1/8, 1/4, 1/2, 3/4, 1, 1.5, 2, 3, 4, 6, 8, 12, 16, 24, 32, 36, 48\*, 64†, 72† : Choose the selectable screen range.

\*MR-1000TII/TIII

†MR-1000TIII only

### ◇ SETUP MEMORY

- The present setting value is displayed by pushing [▶], then select the desired item from “RECALL” and “SAVE” using with [▼].

① Push [▶] to display “RECALL” and “SAVE”.

② Push [▲ ▼] to select “RECALL” or “SAVE”.

③ Push [▶].

- “SURE ?” is displayed.

④ Push [▶] to perform.

⑤ Push [◀] to cancel.

- When recall is performed without saving a setup, it will become an initial value at the time of factory shipments.

### ◇ Other readouts

#### •OUTPUT VOLTAGE

: Shows the voltage level for the scanner unit from the display unit.

- HV (High voltage): Shows the voltage level in the high-voltage unit in the scanner unit.

- MONITOR : Shows the voltage level for checking the receiver unit operation.

- HEATER : Shows the heater current.

- MG : Shows the current level for the Magnetron.

- TX TIME : Shows the total transmitted time.

## ■ TIMING adjustment

The system cable length affects the sweep timing. When the cable length adjustment is not correct, a straight target is shown as a curved echo. Thus, cable length adjustment is necessary.

- ① Position your boat near a straight target such as breakwater, wharf, etc.
- ② Push [-]/[量程-] several times to select 1/8 or 1/4 NM range.

- ③ Push [TX (SAVE)]/[发射(节电)] to display the target on the screen.
- ④ Push [MENU]/[菜单], [▼] and [▶] several times to display the "SERVICE MAN" menu.
- ⑤ Push [▼] until the "TIMING ADJ." section becomes highlighted.
- ⑥ Push [◀ ▶] to adjust the echo until it becomes straight. (see below)
- ⑦ Push [MENU]/[菜单] to return to the normal screen.

Proper adjustment

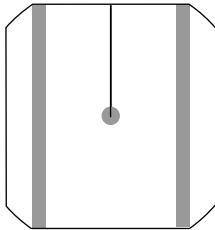

Improper, pulling inward

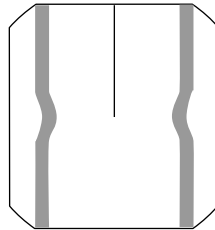

Improper, pushing outward

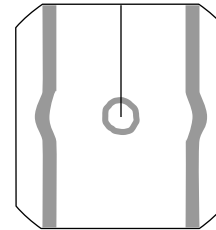

## ■ HDG adjustment

If the heading marker line differs from the exact bow direction, correct the heading marker line as follows. This function may be helpful when the scanner has not been mounted exactly in the direction of the bow.

- ① Line up the bow of the boat with an identifiable target.
- ② Push [TX (SAVE)]/[发射(节电)] to display the target on the screen.
- ③ Push [MENU]/[菜单], [▼] and [▶] several times to display the "SERVICE MAN" menu.
- ④ Push [▼] until the "HDG ADJ." section becomes highlighted.
- ⑤ Push [◀ ▶] to adjust, until the target matches the heading marker. (the difference can be read out on the menu screen)
- ⑥ Push [MENU]/[菜单] to return to the normal screen.

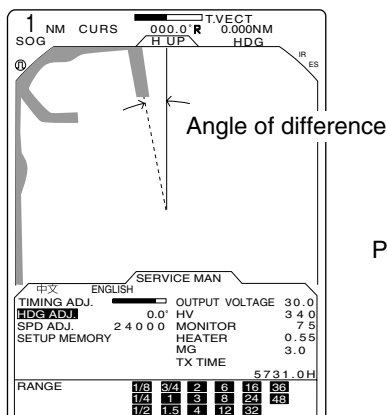

Push [◀ ▶]  
→

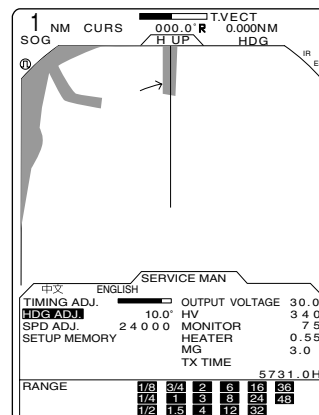

## ■ SPD adjustment

- ① Push [MENU]/[菜单], [▼] and [▶] several times to display the “SERVICE MAN” menu.
- ② Push [▼] until the “SPD ADJ.” section becomes highlighted.
- ③ Push [◀ ▶] to enter the pulse rate (pulse numbers per one nautical mile) of the speed sensor unit.
- ④ Push [MENU]/[菜单] to return to the normal screen.

## ■ RANGE selection

中文		ENGLISH		SERVICE MAN	
TIMING ADJ.	<input type="checkbox"/>	OUTPUT VOLTAGE	30.0		
HDG ADJ.	0.0°	HV	3 4 0		
SPD ADJ.	2 4 0 0 0	MONITOR	7 5		
SETUP MEMORY		HEATER	0.5 5		
		MG	3.0		
		TX TIME	5 7 3 1.0 H		
<b>RANGE</b>	<b>1/8</b>	<b>3/4</b>	<b>2</b>	<b>6</b>	<b>16</b>
	<b>1/4</b>	<b>1</b>	<b>3</b>	<b>8</b>	<b>24</b>
	<b>1/2</b>	<b>1.5</b>	<b>4</b>	<b>12</b>	<b>32</b>
				<b>36</b>	<b>72</b>
				<b>48</b>	
				<b>64</b>	

\*1/4 NM range will be skipped.

- ① Push [MENU]/[菜单], [▼] and [▶] to display the “SERVICE MAN” menu.
- ② Push [▼] until the “RANGE” section becomes highlighted.
- ③ Push [▲ ▼] to choose the selectable screen ranges with [+]/[量程+] or [-]/[量程-] on the display.
- ④ Push [◀] to skip from the range selection, or push [▶] to cancel skipping.
- ⑤ Push [MENU]/[菜单] to return to the normal screen.

Selectable ranges: 1/8, 1/4, 1/2, 3/4, 1, 1.5, 2, 3, 4, 6, 8, 12, 16, 24, 32, 36, 48\*, 64†, 72† (NM)

\*48 NM range is available for the MR-1000TII/TIII.

†64 and 72 NM ranges are available for the MR-1000TIII only.

## ■ Error message list

Message	Condition
BRG INPUT FAIL *1 输入包围不良	• The Azimuth signal is interrupted. An alarm tone is emitted within 5 sec. and the display reverts to H UP mode in approx. 1 min.
TRIG SIGNAL FAIL *1 触发信号不良	• If the TRIGGER signal is interrupted for more than 15 sec., an alarm tone is emitted.
SHM SIGNAL FAIL *2 船首纜信号不良	• If the SHM signal is interrupted for more than 15 sec., an alarm tone is emitted.
POSN INPUT FAIL *1 船位输入不良	• If the position signal is interrupted for more than 15 sec., an alarm tone is emitted.
CHECK SCANNER CONNECTION*4 检查天纜接触	• The system cable may not be connected properly.

\*1 Push any key to cancel the error message and beep tone. Turn the power OFF, then check the external data cable connection.

\*2 An electricity failure may occur, turn the power OFF, then consult your dealer or service man.

\*3 Push any key to cancel the error message and beep tone.

\*4 Turn the power OFF, then check the system cable connections.

# 13 MAINTENANCE

Continued, reliable operation of the radar depends on how you care for your equipment. The simple maintenance tips that follow can help you save time and money, and avoid premature equipment failures.

## ■ Periodic maintenance

**WARNING: BE SURE** the power is **OFF** before performing any maintenance.

- ① Keep the equipment as clean as possible.
  - Use a soft cloth to remove dirt, dust and water.
- ② Check all hardware for loose screws, bolts, etc.
- ③ Check cables and terminal connections.

## ■ Scanner unit maintenance

**WARNING: BE SURE** the power is **OFF** before working on the radar.

### ◇ Cleaning

- ① Wipe the surface of the scanner with a clean soft cloth.
  - DO NOT use strong solvents such as benzene or alcohol.
- ② Check that there is no drift or caked salt.
  - A heavy deposit of dirt or caked salt on the painted surface of the upper scanner unit will cause a considerable drop in radar performance.
- ③ Check for cracks or deterioration of the rubber packing and replace it if necessary.

### ◇ Painting (MR-1000TII/TIII)

To prevent the corrosion, paint the surface of the scanner body (except the antenna unit) twice a year or more.

### ◇ Mounting

Check the mounting bolts of the scanner unit and tighten if necessary.

## ■ Display unit maintenance

**WARNING: BE SURE** the power is **OFF** before working on the radar.

### ◇ Cleaning

Dirt on the CRT will, in time, leave a film of contaminants which tend to dim the picture.

- ① Wipe the surface of the display unit with a clean soft cloth.
  - DO NOT use strong solvents such as benzene or alcohol.
- ② If the picture is still dim, clean the CRT screen.

## ■ Options

### • OPC-1077A SYSTEM CABLE

Allows you to install the display unit and scanner up to 20 m (65<sup>5</sup>/<sub>8</sub> ft) apart.

### • OPC-1078A SYSTEM CABLE

Allows you to install the display unit and scanner up to 30 m (98<sup>7</sup>/<sub>16</sub> ft) apart.



## ◆ General

- Minimum range : 25 m; 82 ft (when measurement range is 1/8 NM)
- Maximum range : 36 NM (MR-1000RII; when measurement range is 36 NM)  
48 NM (MR-1000TII; when measurement range is 48 NM)
- Measurement range : 1/8, 1/4, 1/2, 3/4, 1, 1.5, 2, 3, 4, 6, 8, 12, 16, 24, 32, 36, 48\*,  
64†, 72† (NM) \*MR-1000TII/TIII, †MR-1000TIII only
- Preheat time : 90 sec.
- Connection length between display and scanner unit : 15 m; 49<sup>7</sup>/<sub>32</sub> ft (MR-1000RII),  
20 m; 65<sup>5</sup>/<sub>8</sub> ft (MR-1000TII/TIII, optional for MR-1000RII),  
30 m; 98<sup>7</sup>/<sub>16</sub> (optional)

## ◆ Scanner unit

### ◆ EX-2714 (Radome)

- Type : 2 feet Slotted Waveguide Array, enclosed in a radome.
- Rotation speed (typical) : 24 rpm, 36 rpm, 48 rpm
- Beam width (typical) : Horizontal beam 4°  
Vertical beam 22°
- Side lobe (typical) : -18 dB
- Polarization : Horizontal
- Transmission frequency : 9410 MHz ±30 MHz P0N
- Peak output power : 4 kW
- Pulse width : 80 ns/2880 Hz, 80 ns/2160 Hz, 250 ns/2160 Hz,  
350 ns/2160 Hz, 900 ns/720 Hz.
- Mixer and Local Oscillator : Microwave Integrated Circuit
- Transmitting Tube : Magnetron MAF1421B
- Modulator : FET switching
- Duplexer : Circulator
- Tuning system : Automatic/manual selectable
- Intermediate frequency : 60 MHz
- IF Band width : 10 MHz, 3 MHz
- Dimensions : 607 (Ø)×243 (H) mm; 23<sup>29</sup>/<sub>32</sub> (Ø)×9<sup>9</sup>/<sub>16</sub> (H) in
- Usable temperature range : -25°C to +70°C; -13°F to 158°F
- Relative Humidity : Less than 95% at 35°C (+95°F)
- Weight : Approx. 8 kg; 17<sup>5</sup>/<sub>8</sub> lb (without cable)

### ◆ EX-2780 (Open array)

- Type : 120 cm Slotted Waveguide Array
- Rotation speed (typical) : 22 rpm (MR-1000TIII only), 24 rpm, 36 rpm, 48 rpm
- Beam width (typical) : Horizontal beam 2°  
Vertical beam 25°
- Side lobe (typical) : -24 dB
- Polarization : Horizontal
- Transmission frequency : 9410 MHz ±30 MHz P0N
- Peak output power : 4 kW (MR-1000TII), 6 kW (MR-1000TIII)
- Pulse width : 80 ns/2880Hz, 80 ns/2160 Hz, 250 ns/2160 Hz,  
350 ns/2160 Hz, 900 ns/720 Hz, 900 ns/660 Hz\*  
\*MR-1000TIII only
- Mixer and Local Oscillator : Microwave Integrated Circuit
- Transmitting Tube : Magnetron MAF1421B (MR-1000TII)  
MAF1422B (MR-1000TIII)
- Modulator : FET switching
- Duplexer : Circulator
- Tuning system : Automatic/manual selectable
- Intermediate frequency : 60 MHz
- IF Band width : 10 MHz, 3 MHz
- Diameter of rotation/height : 1205/381 mm; 47<sup>7</sup>/<sub>16</sub>/15 in
- Usable temperature range : -25°C to +70°C; -13°F to 158°F
- Relative Humidity : Less than 95% at 35°C (+95°F)
- Weight : Approx. 17 kg; 37<sup>15</sup>/<sub>32</sub> lb (without cable)

### ◇ Display unit

- CRT display : 10-inch green display
- Pixels : 640×480 dot
- CRT mounting : Vertical
- Input : NMEA 0183 format (for navigation receiver) ; N+1 format (flux gate compass sensor), AUX
- Power supply requirement : 10.2 to 42 V DC
- Power consumption (at wind velocity zero) : Approx. 60 W (MR-1000RII)  
Approx. 70 W (MR-1000TII)  
Approx. 80 W (MR-1000TIII)
- Usable temperature range : -15°C to +55°C; +5°F to 131°F
- Relative humidity : Less than 95% at 35°C (+95°F)
- Dimensions : 269 (W)×264 (H)×258 (D) mm  
; 10<sup>19/32</sup> (W)×10<sup>13/32</sup> (H)×10<sup>5/32</sup> (D) in
- Weight : Approx. 6.5 kg; 14<sup>5/16</sup> lb

# EXTERNAL DATA LIST 15

The following external bearing, speed, position and way point data is (are) required , when you use the radar functions.

			EXTERNAL DATA INPUT			
			NMEA1*2	NMEA2*2		
			"HDT", "HDM" N+1, AUX	"RMC", "GGA", "GLL", "VTG", "WPL", "BWC", LOG, "GNS"		
FUNCTION		DISPLAY	BEARING	SPEED	POSITION	WAY POINT
HEAD UP		HU				
COURSE UP		CU	Required			
NORTH UP		NU	Required			
TRUE MOTION	OG*1	TM	Required		"RMC", "GGA" or "GLL", "GNS"	
	TW*1	TM	Required	LOG		
SPEED DISPLAY	OG*1	SOG		"RMC" or "VTG"		
	TW*1	STW		LOG		
HEADING BEARING		HDG	Required			
WAY POINT		WPT	Required		"RMC", "GGA" or "GLL", "GNS"	"WPL" or "BWC"
OWN VECTOR	OG*1		Required	"RMC" or "VTG"		
	TW*1		Required	LOG		
MOB		MOB	Required		"RMC", "GGA" or "GLL", "GNS"	
ATA	OG*1	ATA	Required	"RMC" or "VTG"		
	TW*1	ATA	Required	LOG		
VRM/PI/WPT/MOB estimated time of arrival	OG*1			"RMC" or "VTG"		
	TW*1			LOG		
MAGNETIC VARIATION (AUTO)				"RMC" or "VTG"		

\*1 OG; Over ground, TW; Through the water

\*2 NMEA1 and NMEA2 connectors; See p. 24

- "HDT", "HDM", "RMC", "GGA", "GLL", "VTG", "WPL", "GNS" and "BWC" are SENTENCES of the NMEA0183.
- If BRG INPUT is set to "GPS", "RMC" of NMEA2 connector or COG (Course Over the Ground) of "VTG" a bow it receives as a direction, even if there is no direction information (compass etc.) in NMEA1 connector, the screen display of the North rise etc. is possible.

However, direction accuracy falls when the speed of a ship is set to 2 or less kts, or when exceeding 3 kts a bow it does not receive as direction data. Moreo, the influence of measurement position accuracy or a current an actual bow it may differ from a direction.

• **SX-2713/2779**  
**Display mounting bracket template**

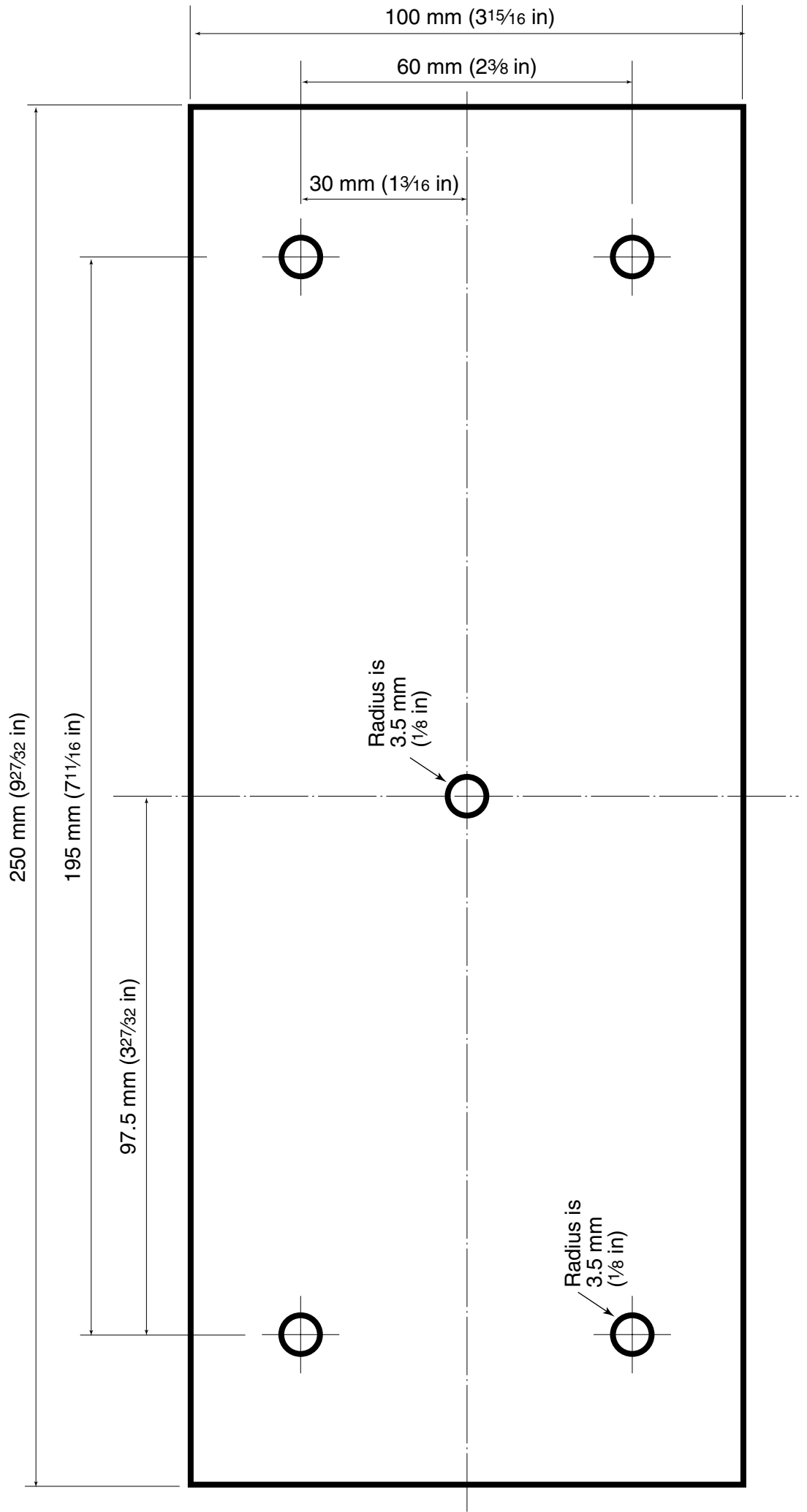

• EX-2714 Radome template

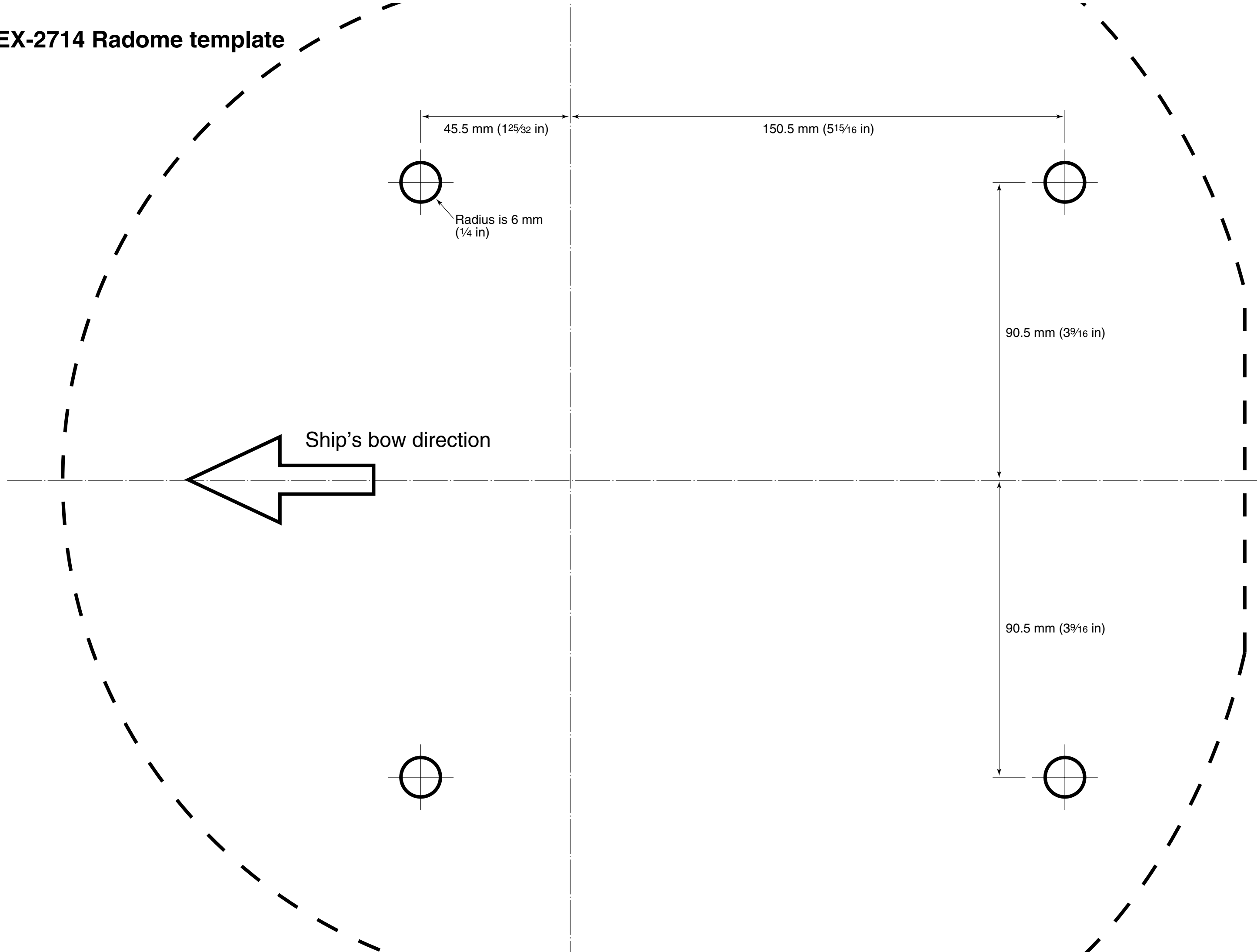

•EX-2780  
Open array type  
template

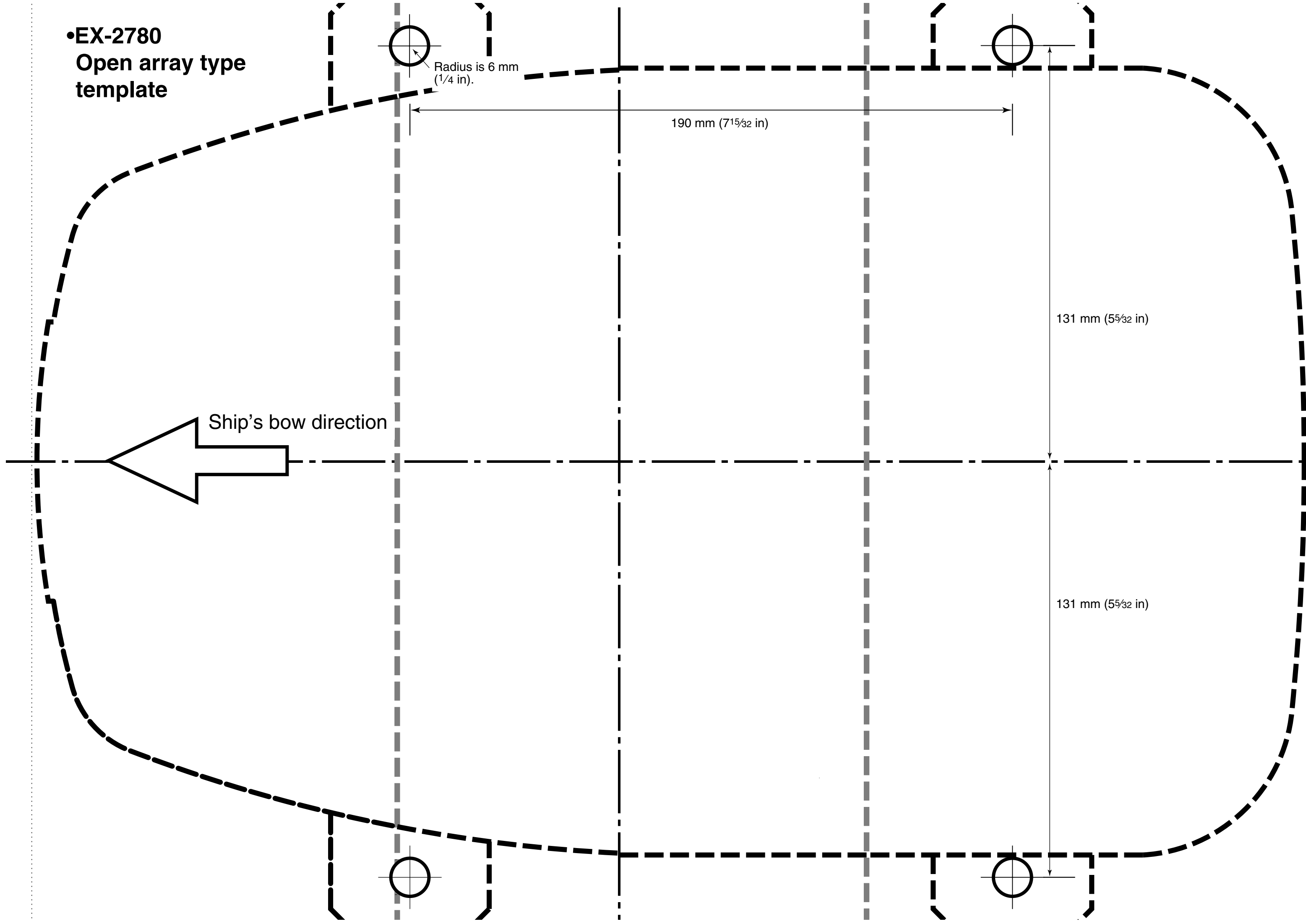

**Count on us!**

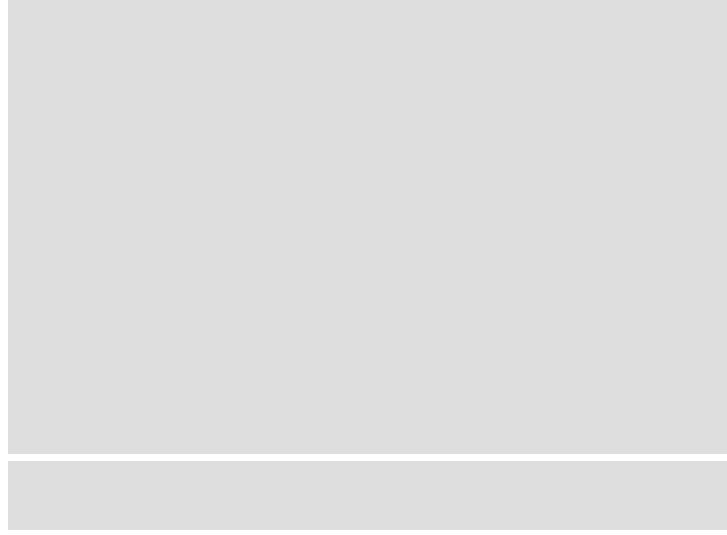

---

---

---

---

---